



Universidad de Concepción
Dirección de Postgrado
Facultad de Ciencias Físicas y Matemáticas
Programa de Doctorado en Matemáticas

VARIATIONAL LIMITS OF PROBLEMS IN
JUNCTION DOMAINS FOR FERROELECTRIC
AND HYPERELASTIC MATERIALS BY
REDUCTION OF DIMENSION



Pedro L. Hernández-Llanos

Dissertation

Submitted in partial fulfillment of the requirements
for the degree of **Doctor of Philosophy in Mathematics**
Concepción, Chile, September 25, 2020



**PROBLEMAS LÍMITES EN LA MODELIZACIÓN DE FENÓMENOS
FERRO-ELÉCTRICOS E HIPERELÁSTICOS EN LA UNIÓN DE DOMINIOS
POR REDUCCIÓN DE DIMENSIÓN.**

**VARIATIONAL LIMITS OF PROBLEMS IN JUNCTION DOMAINS FOR
FERROELECTRIC AND HYPERELASTIC MATERIALS BY REDUCTION OF
DIMENSION.**



Pedro L. Hernández -Llanos

Tesis Doctoral

Concepción, Chile, Septiembre 2020



Universidad de Concepción
Dirección de Postgrado
Facultad de Ciencias Físicas y Matemáticas
Programa de Doctorado en Matemáticas

**PROBLEMAS LÍMITES EN LA MODELIZACIÓN DE FENÓMENOS
FERRO-ELÉCTRICOS E HIPERELÁSTICOS EN LA UNIÓN DE DOMINIOS
POR REDUCCIÓN DE DIMENSIÓN.**

**VARIATIONAL LIMITS OF PROBLEMS IN JUNCTION DOMAINS FOR
FERROELECTRIC AND HYPERELASTIC MATERIALS BY REDUCTION OF
DIMENSION.**

Pedro L. Hernández-Llanos

Profesor Guía: **Rajesh Mahadevan** †

Profesor Coguía: **Ravi Prakash** †

† Departamento de Matemáticas,
Universidad de Concepción (UdeC)

Concepción, Chile, Septiembre 2020



Universidad de Concepción

Dirección de Postgrado

Facultad de Ciencias Físicas y Matemáticas

Programa de Doctorado en Matemáticas

**VARIATIONAL LIMITS OF PROBLEMS IN JUNCTION DOMAINS FOR FERROELECTRIC
AND HYPERELASTIC MATERIALS BY REDUCTION OF DIMENSION**

Pedro L. Hernández-Llanos

Profesor guía: Rajesh Mahadevan
Universidad de Concepción, Chile.

Codirector: Ravi Prakash
Universidad de Concepción, Chile.



Evaluable externo: Umberto De Maio
Università degli studi di Napoli "Federico II", Italy.

Evaluable externo: Carlos Conca
Universidad de Chile, Chile.

Evaluable externo: Igor Velčić
University of Zagreb, Croatia.

Thesis defended on:
Pedro L. Hernández-Llanos
Concepción, Chile, 2020.



To God, my wife, my parents, my sisters Diana Patricia and Adriana.

Introduction

A thin structure is a three-dimensional object with one preponderant dimension, such as a wire, rod, beam, a combination of wires or two preponderant dimensions such as in thin films, thin plates, shell structures etc.

In this thesis, we are interested in studying physical phenomena which take place in such domains, more precisely, phenomena of ferro-electricity and hyper-elasticity in the union of thin structures of a one-dimensional nature.

Although the study of ferroelectricity dates back to the 1920s, only recently theoretical models for such phenomena in thin structures have been proposed. Gaudiello and Hamdache [46] proposed a rigorous 2D–variational model for a thin film starting from classical non-convex and nonlocal 3D–variational model of the electric polarization in a ferroelectric material, via an asymptotic process.

Let

$$\Omega_n = \omega \times \left] -\frac{h_n}{2}, \frac{h_n}{2} \right[, \quad n \in \mathbb{N},$$

be a 3D ferroelectric device with open polygonal cross-section $\omega \subset \mathbb{R}^2$ and small thickness h_n , where $h_n \in]0, 1[$, $n \in \mathbb{N}$, is a parameter tending to zero. Since the free energy associated with Ω_n is non-convex, nonlocal and it is given by (for instance, see [22, 71, 76]).

$$\begin{aligned} \mathcal{E}_n : \mathbf{p} = (p_1, p_2, p_3) &\in \left(H^1(\Omega_n) \right)^3 \\ &\rightarrow \frac{1}{|\Omega_n|} \int_{\Omega_n} \left(\beta |\operatorname{rot} \mathbf{p}|^2 + |\operatorname{div} \mathbf{p}|^2 + \alpha (|\mathbf{p}|^2 - 1)^2 - |\mathbf{D}\varphi_{\mathbf{p}}|^2 + (\mathbf{g}_n \cdot \mathbf{p}) \right) dx, \end{aligned} \quad (1)$$

where $\varphi_{\mathbf{p}}$ is the unique solution of the problem

$$\varphi_{\mathbf{p}} \in H^1(\Omega_n), \quad \int_{\Omega_n} \varphi_{\mathbf{p}} \, dx = 0, \quad \int_{\Omega_n} ((-\mathbf{D}\varphi_{\mathbf{p}} + \mathbf{p}) \cdot \mathbf{D}\varphi) \, dx = 0, \quad \forall \varphi \in H^1(\Omega_n),$$

for every $n \in \mathbb{N}$ and $\mathbf{p} \in (L^2(\Omega_n))^3$, $\alpha = -\frac{T-T_C}{T_C}$ is the reduced temperature which verifies $0 < \alpha < 1$ since temperature T is assumed smaller than Curie temperature T_C , $\beta > 0$ is a positive constant, $\mathbf{g}_n \in (L^2(\Omega_n))^3$ is an external electric field and \mathbf{p} is the spontaneous electric polarization field. Depending on the initial boundary conditions, the limit problem can be either nonlocal or local. For the boundary condition,

$$\mathbf{p} \cdot \boldsymbol{\nu} = 0 \quad \text{on } \partial\Omega_n \quad (2)$$

imposing appropriate convergence assumptions on the rescaled exterior field in $\Omega = \omega \times \left] -\frac{1}{2}, \frac{1}{2} \right]$, they prove that

$$\lim_n \min \left\{ E_n(\mathbf{p}) : \mathbf{p} \in (H^1(\Omega))^3, \quad \mathbf{p} \cdot \boldsymbol{\nu} = 0 \quad \text{on } \partial\Omega \right\} = \min \{ \mathcal{E}_\infty(\mathbf{q}) : \mathbf{q} \in P_\infty \},$$

where the functional E_n , is the rescaled version of \mathcal{E}_n defined in (1) which is given by

$$E_n : \mathbf{p} \rightarrow \int_{\Omega} \left(\beta |\text{rot}_n \mathbf{p}|^2 + |\text{div}_n \mathbf{p}|^2 + \alpha (|\mathbf{p}|^2 - 1)^2 - |\mathbf{D}_n \varphi_{\mathbf{p}}|^2 + (\mathbf{f}_n \cdot \mathbf{p}) \right) dx,$$

where $\varphi_{\mathbf{p}}$ is the unique solution of the problem

$$\varphi_{\mathbf{p}} \in H^1(\Omega), \quad \int_{\Omega} \varphi_{\mathbf{p}} \, dx = 0, \quad \int_{\Omega} ((-\mathbf{D}_n \varphi_{\mathbf{p}} + \mathbf{p}) \cdot \mathbf{D}_n \varphi) \, dx = 0, \quad \forall \varphi \in H^1(\Omega),$$

$$\begin{aligned} P_\infty &= \left\{ \mathbf{q} \in (H^1(\Omega))^2, \quad \mathbf{q} \text{ is independent of } x_3 \text{ and } \mathbf{q} \cdot \boldsymbol{\nu}' = 0 \text{ on } \partial\omega \times \left] -\frac{1}{2}, \frac{1}{2} \right] \right\}, \\ &= \left\{ \mathbf{q} \in (H^1(\omega))^2 : \mathbf{q} \cdot \boldsymbol{\nu}' = 0 \text{ on } \partial\omega \right\} \end{aligned}$$

and

$$\mathcal{E}_\infty : \mathbf{q} \rightarrow \int_{\omega} \left(\beta |\text{rot } \mathbf{q}|^2 + |\text{div } \mathbf{q}|^2 + \alpha (|\mathbf{q}|^2 - 1)^2 - |\mathbf{D}\varphi_{\mathbf{q}}|^2 + \int_{-\frac{1}{2}}^{\frac{1}{2}} ((f_1, f_2) \, dx_3 \cdot \mathbf{q}) \right) dx'.$$

Also, in 2015, the same authors [47] proposed a reduced model for electrical polarization in a ferroelectric wire, where starting from a non-convex and nonlocal 3D-variational model for the electric po-

larization in a ferroelectric material, via an asymptotic process they obtain a rigorous 1D–variational model for a thin wire. Precisely, here let

$$\Omega_n = (h_n \omega) \times \left] -\frac{1}{2}, \frac{1}{2} \right[, \quad n \in \mathbb{N},$$

be a 3D ferroelectric cylindrical device with small cross-section $h_n \omega$ and thickness 1, where $h_n \in]0, 1[$, $n \in \mathbb{N}$, is a parameter tending to zero and $\omega \subset \mathbb{R}^2$ is an open polygonal set. Starting from the free energy associated with Ω_n is non-convex, nonlocal (1) with the boundary condition (2) and imposing appropriate convergence assumptions on the rescaled exterior field in $\Omega = \omega \times \left] -\frac{1}{2}, \frac{1}{2} \right[$, they prove that

$$\lim_n \min \left\{ E_n(\mathbf{p}) : \mathbf{p} \in (H^1(\Omega))^3, \quad \mathbf{p} \cdot \nu = 0 \quad \text{on} \quad \partial\Omega \right\} = \min \{ E_\infty(q) : q \in H_0^1 \left(] -\frac{1}{2}, \frac{1}{2} [\right) \},$$

where the functional E_n , is given by (3) and

$$E_\infty : q \mapsto \beta |\omega| \int_{-\frac{1}{2}}^{\frac{1}{2}} \left| \frac{dq}{dx_3} \right|^2 dx_3 + \alpha |\omega| \int_{-\frac{1}{2}}^{\frac{1}{2}} (|q|^2 - 1)^2 dx_3 + \left(\frac{4\pi}{\varepsilon} \right)^2 |\omega| \int_{-\frac{1}{2}}^{\frac{1}{2}} |q|^2 dx_3 - \int_{-\frac{1}{2}}^{\frac{1}{2}} \bar{g}_3 q dx_3,$$

with $\bar{g} = (\bar{g}_1, \bar{g}_2, \bar{g}_3)$ and where ε is the dielectric permeability.

Recently, Carbone et. al. [16] starting from a non-convex and nonlocal 3D–variational model for the electric polarization in a ferroelectric material (1), and using an asymptotic process based on dimensional reduction analyze junction phenomena for two orthogonal joined ferroelectric thin films and obtain three different 2D–variational models for joined thin films, depending on how the reduction happens.

Another important phenomenon of interest for the scientific community is elasticity of thin structures plates, shells, rods and beams. Although two-dimensional or one-dimensional models for elastic structures have been widely known for a long time since Euler, Kirchhoff, Love, Von Kármán and others, rigorous justification of these reduced models starting from three-dimensional elasticity has made progress only in the last 30 years. Given a body $\Omega^h \subset \mathbb{R}^3$ made of the same nonlinear hyperelastic material with thickness h , for a deformation $\mathbf{u} \in H^1(\Omega^h; \mathbb{R}^3)$ of the thin structure the elastic energy per unit thickness is given by

$$\mathcal{E}^h(\mathbf{u}) = \frac{1}{h} \int_{\Omega^h} W(\nabla \mathbf{u}) dx,$$

where W is the so-called stored energy function. The general objective is to obtain an asymptotic rep-

resentation of the energy as $h \rightarrow 0$ in the variational sense, usually, in the Γ -convergence framework under specific hypothesis on the forces to which the structure is subjected.

As regards rigorous one-dimensional reduced models, one of the first results in this direction is due Acerbi et al. [1] who deduced a nonlinear model for elastic strings by means of a reduction from three dimensions to one. They denote by Σ the reference configuration of the string:

$$\Sigma = \{(x_1, x_2, x_3) : 0 \leq x_1 \leq 1, x_2 = x_3 = 0\},$$

and by Σ_ε the “thick” elastic body $\Sigma_\varepsilon = \{(x_1, x_2, x_3) : 0 \leq x_1 \leq 1, x_2^2 + x_3^2 \leq \varepsilon^2\}$. They assume the stored strain energy, associated to a displacement field u , to be given by a functional of the form

$$\int_{\Sigma_\varepsilon} f(\nabla u) \, dx,$$

where $f : \mathbb{R}^{3 \times 3} \rightarrow [0, +\infty]$ is a suitable function, in general not convex. Assuming also that the exterior loads derive from a potential of the form $u^2 + g(x)u$, the equilibrium configuration of the body Σ_ε is given by the solution u_ε of the minimization problem

$$\min \left\{ \int_{\Sigma_\varepsilon} [f(\nabla u) + u^2 + g(x)u] \, dx \right\},$$

where the minimum is taken over all functions u belonging to some Sobolev Space $W^{1,p}(\Sigma_\varepsilon; \mathbb{R}^3)$ and they prove that if $\varepsilon \rightarrow 0$, then u_ε converges in an appropriate sense to a function u_0 defined on Σ , and this function u_0 turns out to be a solution of the variational (limit) problem

$$\min \left\{ \int_{\Sigma} [f_0^{**}(u') + u^2 + g(x_1, 0, 0)u] \, dx_1 \right\},$$

where $f_0(z) = \inf\{f(z|\alpha|\beta); \alpha, \beta \in \mathbb{R}^3\}$ and f_0^{**} denotes the convex envelope of f_0 .

The two-dimensional analogue was studied by Le Dret and Raoult [58, 59], who derived nonlinear models for thin homogeneous plates membranes and shells membranes. In the main work [59], they deduced that the total energy behavior in terms of the rescaled displacement v for a family of shells $\tilde{\Omega}_\varepsilon$ with thickness $\varepsilon > 0$ made of the same nonlinear hyperelastic homogeneous material which is subjected to surface forces $g(\varepsilon)$ and generated by the diffeomorphism $\Psi : \Omega_\varepsilon \rightarrow \tilde{\Omega}_\varepsilon$ given by

$$\Psi(x_1, x_2, x_3) = \psi(x_1, x_2) + x_3 a_3(x_1, x_2),$$

where $\Omega_\varepsilon = \omega \times]-\varepsilon, \varepsilon[$ with $\omega \subset \mathbb{R}^2$ open and bounded set, is given in curvilinear coordinates and

over the rescaled domain $\Omega = \omega \times]-1, 1[$ by

$$J(\varepsilon)(v) = \int_{\Omega} W \left(\left(\partial_1 v | \partial_2 v | \frac{\partial_3 v}{\varepsilon} \right) A(\varepsilon)^{-1} + I \right) \det A(\varepsilon) dx \\ - \int_{S^{\pm}} \varepsilon^{-1} g(\varepsilon) \cdot (v + \Psi(\varepsilon)) \| \text{Cof } A(\varepsilon) e_3 \| d\sigma,$$

where,

$$A(\varepsilon)(x) = \nabla \Psi(x_1, x_2, \varepsilon x_3) = A(x_1, x_2) + \varepsilon x_3 (\partial a_3(x_1, x_2) | \partial_2 a_3(x_1, x_2) | 0).$$

Under assumptions specific on the surface forces $g(\varepsilon)$ and the stored energy function W , by dimension-reduction and Γ -convergence, the authors obtained that the sequence $J^*(\varepsilon)$ Γ -converges in the strong topology of $L^p(\Omega; \mathbb{R}^3)$ when $\varepsilon \rightarrow 0$. Let $J^*(0)$ be its Γ -limit. For all $v \in L^p(\Omega; \mathbb{R}^3)$, $J^*(v)(0)$ is given by

$$J^*(0) = \begin{cases} 2 \int_{\omega} QW_0(x, (a_1 + \partial_1 \bar{v} | a_2 + \partial_2 \bar{v})) \sqrt{a} dx_1 dx_2 - \int_{\omega} \mathcal{G} \cdot (\psi + \bar{v}) \sqrt{a} dx_1 dx_2, & \text{if } v \in V_M, \\ +\infty, & \text{otherwise,} \end{cases}$$

where $V_M = \left\{ v \in W_{\Gamma}^{1,p}(\Omega; \mathbb{R}^3); \partial_3 v = 0 \right\}$,

$$\forall v \in L^p(\Omega; \mathbb{R}^3), \quad J^*(\varepsilon)(v) = \begin{cases} J(\varepsilon)(v), & \text{if } v \in W_{\Gamma}^{1,p}(\Omega; \mathbb{R}^3), \\ +\infty, & \text{otherwise,} \end{cases}$$

$\mathcal{G} = g(x_1, x_2, 1) + g(x_1, x_2, -1)$, $\sqrt{a} = \det A(x)$ and QW_0 is the quasiconvex envelope of $W_0 : \bar{\omega} \times \mathbb{R}^{3 \times 2} \rightarrow \mathbb{R}$

$$W_0(x, \bar{F}) = \inf_{z \in \mathbb{R}^3} W \left((\bar{F}|z) A^{-1}(x) \right).$$

During recent years interesting contributions on this nonlinear elasticity framework have been made by Friesecke et al. [38, 37, 40], Babadjian and Baía [7], Lewicka et al. [60, 62, 61], Hornung and Velčić [73, 74, 75, 54, 55] among others.

Based on the above two contexts involving ferroelectric material and nonlinear hyperelasticity for homogeneous material it is worth asking the following questions:

1. Is it possible to determine new ferroelectric models for T-junction of thin wires extending that given by Gaudiello et al. in [47] for a thin wire only?

2. Is it possible to determine new nonlinearly hyperelastic models for T-junction of thin beams extending that given by Acerbi et al. in [1]?

Our main results in the thesis concern 3D – 1D models related to ferroelectric and nonlinearly hyperelastic problems in thin multi-structures which are obtained through dimension-reduction and Γ -convergence.

The work is structured into three chapters whose contents are briefly described below.

Chapter I is essentially an introduction to Γ -convergence theory essential for the study of the problems of thin structures and multi-structures. We also briefly describe the basic ferroelectric, elastic and hyperelastic models which form the starting points of the analysis.

In Chapter II, starting from a 3D-variational model for ferroelectric devices and using an asymptotic process based on dimensional reduction, we analyze junction phenomena in a fin-like structure composed of two orthogonal joined ferroelectric thin cylinders (see Figure 3.1). Such a structure appears in some types of non-planar transistor used in the design of modern processors, the so-called Fin Field Effect Transistor (FinFET). We obtain different 1D-variational models depending on the various boundary conditions. In Section 2.2, the initial problem is rescaled on a fixed domain independent of the thickness parameter. Section 2.3 is devoted to the introduction of the constant η defined in (2.9) which appears in the limit of the nonlocal term. Section 2.4 is the heart of the chapter. In accordance with any of the several boundary conditions on the polarization, different limit behaviors of the polarization are expected, and consequently also different behaviors of the nonlocal term could be produced. Indeed, in Proposition 2.4.2, we prove that if the potential generating the nonlocal term is the solution to problem (2.2), then really the limit of the nonlocal term depends on boundary conditions on the polarization and we give a very general formula for the limit of the nonlocal term which covers all the possible cases coming from several boundary conditions on the polarization. If the potential generating the nonlocal term is the solution to problem (2.3), in Proposition 2.4.3, we prove that the limit of the nonlocal term is independent of the boundary conditions on the polarization and, precisely, it is always zero. Finally, using the main ideas of the Γ -convergence method introduced in [33] (see also [12], [32], and [17]), in Sections 2.5, 2.6, 2.7, and 2.8 we study the asymptotic behavior of problems (2.4), (2.5), (2.6), and (2.15), respectively, obtaining L^2 -strong convergences on the rescaled polarization p_n , on the rescaled potential φ_{p_n} , and on their rescaled gradients. In Section 2.9, we just sketch what happens when the potential generating the nonlocal term is the solution to problem (2.3). The results of this chapter appear in our article [18].

Finally, in Chapter III, we consider a nonlinearly hyperelastic material structure having the form of a T-shaped multi-domain composed of two orthogonal joined thin beams whose thicknesses go to

zero. We show, under appropriate hypotheses on the loads, that the deformations that minimize the total energy weakly converge in a Sobolev space towards the minimum of a 1D–dimensional energy. This energy is obtained by Γ –convergence. The chapter is organized as follows: Section 3.2 begins with the basic background about our multidomain in the context of 3D elasticity. Then it is followed by a rescaling of the problem and we define the appropriate Sobolev spaces for the deformations and displacements involved in the rescaled problem. The main result (Theorem 3.1) of the chapter is given in Subsection 3.2.4. We begin Section 3.3 with Lemma 3.1 and Propositions 2.6.1, 2.4.1 and, Theorem 3.1 is proved with their help. Finally, in Section 3.4, we end by computing the 1D–stored energy in the case of the Saint Venant-Kirchhoff material for the junction (Proposition 2.6.2). The results of this chapter have been submitted for publication.



Contents

APPROVAL OF THE JURY	v
Introduction	ix
Contents	xix
Lists of Figures	xxi
Acknowledgments	xxiii
Abstract	xxv
Resumen	xxvii
I Background material	1
1 Background material	3
1.1 Notation	3
1.2 The Direct Method of the Calculus of Variations and Γ -Convergence	4
1.2.1 Definition and properties of Γ -convergence	7
1.3 Thin structures, ferroelectric and nonlinearly hyperelastic model	10
1.3.1 Thin structures	10

1.3.2	Ferroelectric model	11
1.3.3	Nonlinearly hyperelastic model	13
II	T-junction of ferroelectric wires	19
2	T-junction of ferroelectric wires	21
2.1	Introduction	21
2.2	The rescaled problems	28
2.3	Preliminaries	32
2.4	Two convergence results for the nonlocal term	33
2.5	The asymptotic behavior of problem (2.4)	46
2.5.1	The main result	46
2.5.2	A priori estimates on polarization	47
2.5.3	The proof of Theorem 2.1	49
2.6	The asymptotic behavior of problem (2.5)	50
2.6.1	The main result	50
2.6.2	A priori estimates on polarization	51
2.6.3	A convergence result for problem (2.41)	53
2.6.4	The proof of Theorem 2.2	53
2.7	The asymptotic behavior of problem (2.6)	55
2.7.1	The main result	55
2.7.2	A priori estimates on polarization	56
2.7.3	A convergence result for problem (2.23)	57
2.7.4	Proof of Theorem 2.3	58
2.8	The asymptotic behavior of problem (2.15)	59
2.8.1	The main result	59
2.8.2	A priori estimates on polarization	60
2.8.3	The proof of Theorem 2.4	62
2.9	The asymptotic behavior of all previous problems when the control φ_P satisfies (2.8)	66

III Asymptotic Analysis of a Junction of Hyperelastic Rods	67
3 Asymptotic Analysis of a Junction of Hyperelastic Rods	69
3.1 Introduction	69
3.2 Preliminaries	71
3.2.1 Notation and definitions	71
3.2.2 Setting up of the three-dimensional problem	72
3.2.3 The rescaled problem	73
3.2.4 The main result	76
3.3 Proof of the main theorem	77
3.4 An example	85
REFERENCES	89
Index	95



List of Figures

2.1	The set Ω_n .	22
3.1	The set Ω_ε .	72



Acknowledgments

I Thank God that he is primarily responsible for the successful completion of this work. To Professor Rajesh Mahadevan, I express my gratitude to you that during these almost three years of work, in addition to showing me the path of research in the PDE and the calculus of variations and having infinite patience, for having helped me to mature my character as a researcher. He, through his example, to be simple, dedicated and humble as he is. To reach a happy end in this goal, is, in a large percentage, thanks to him. Thank you very much Professor Rajesh for the financial support through the project of the Vicerrectoría de Investigación y desarrollo (VRID) 218.015.0211.0. I also thank Professor Ravi Prakash, who gave me advice and contributed his valuable comments throughout the process and thanks to his initiation project of the Fondo Nacional de Desarrollo Científico y Tecnológico (FONDECYT) N° 11180551. I must also thank in a very special way Professor Antonio Gaudiello who supported me and suggested wonderful ideas for my thesis and that during my stay at the Università degli Studi di Napoli “Federico II” made my internship one of the most enriching experiences of my life . I should also mention Prof. Gioconda Moscariello Director of the Dipartimento di Matematica e applicazioni “Renato Cacciopoli” and the Professor Luciano Carbone who made the internship to be possible.

To my office colleagues Juan Carlos Guajardo, María Elisa Valdés and Franco Olivares for all the moments we could share.

I must also express my gratitude to the Programa de Formación de Capital Humano Avanzado (PFCHA) of the Comisión Nacional de Investigación Científica y Tecnológica de Chile (CONICYT) and the Dirección de postgrado of the Universidad de Concepción, for not only the economic support,

through the scholarship that I have enjoyed, but also to allow me to fulfill my dream of to exercise some teaching and research activities. Particularly, I want to highlight I was supported by Professor Jacquelin Ojeda, who, as the director of the Mathematics department, helped me to carry out many of the academic support activities that I had the privilege of participating in and who, also at the beginning of this project, provided help and advice.

Finally, I want to highlight the tireless sacrifice and dedication of my wife who has been my unconditional support thanks for the enormous patience enduring the moments of joy and especially those of sadness and the occasional disappointment, She was always attentive to me and her support made this project more bearable. I also want to thank my parents and my sisters for that great support that they offered me through the distance and for being my motivation to advance in my formation.

Pedro Hernández-Llanos



Abstract

In this work, firstly we study the junction phenomena for two joined thin structures in two kind of context, the first: ferroelectricity, starting from a non-convex and nonlocal 3D-variational model for the electric polarization in a T-junction of two orthogonal thin wires made of ferroelectric material, and using an asymptotic process based on dimensional reduction, we obtain different 1D variational models depending of the initially boundary condition, and the second context: hyperelasticity, starting from 3D nonlinear elasticity equations and using dimensional reduction and Γ -convergence analyze junction phenomena for two orthogonal joined thin beams and we obtain a 1D variational model composed of the elastic energy of the vertical beam and the horizontal beam.

Keywords: electric polarization, ferroelectric devices, hyperelasticity, thin wires, junctions, dimension reduction, gamma-convergence.

Resumen

En este trabajo primeramente estudiamos el fenómeno de la unión para dos estructuras en dos tipos de contextos, el primero: ferroelectricidad, iniciando desde un modelo tridimensional variacional no local y no convexo para la polarización eléctrica en una unión en forma de T de dos cables ortogonales hechos de material ferroeléctrico, y usando un proceso asintótico basado en reducción dimensional, obtenemos distintos modelos 1D dependiendo de las condiciones de frontera iniciales. El segundo contexto: hiperelasticidad, a partir de las ecuaciones de elasticidad tridimensional y usando reducción de dimensión y Γ -convergencia analizamos el fenómeno de la unión para dos vigas ortogonales unidas y obtenemos un modelo variacional 1D compuesto de la energía elástica de la viga vertical y la viga horizontal.

Palabras Claves: polarización eléctrica, dispositivos ferroeléctricos, hiperelasticidad, cables delgados, uniones, reducción de dimensión, gamma-convergencia.

PART I

Background material



Background material

This chapter is devoted to summarize the material that constitutes the background for the rest of the thesis. The contents of Section 1.1 are the notations used throughout the work. In Section 1.2, we introduce the main method that has been used in this thesis: the direct method of the calculus of variations and Γ -convergence. In this direction, we recall some properties of Γ -convergence. Finally, in Section 1.3, we recall the notion of a thin structure and the corresponding three dimensional ferroelectric and nonlinear hyperelastic models in existence. A more detailed description of some of the contents of this chapter can be found in [12, 13, 32, 5], among others.

1.1 Notation

Throughout this thesis, we denote by \mathbb{N} , \mathbb{R} , \mathbb{R}^+ and $\mathbb{R}^{m \times n}$ the sets of natural, real, positive real numbers and the space of real $m \times n$ matrices endowed with the usual Euclidean norm for a $m \times n$ -matrix F as $\|F\| = \sqrt{\text{tr } F^T F}$ respectively. In this work, $h = \{h_n\}_{n=1}^\infty$ stands for a generic decreasing sequence of positive numbers such that $\lim_{n \rightarrow \infty} h_n = 0$. We will write a generic point $x \in \mathbb{R}^3$ as

$$x = (x', x_3), \quad \text{where } x' \in \mathbb{R}^2 \quad \text{and} \quad x_3 \in \mathbb{R},$$

and we will use the notation ∇' to denote the gradient with respect to x' . For every $r \in \mathbb{R}$, $[r]$ is its the greatest integer part. With a slight abuse of notation, for every $x' \in \mathbb{R}^2$, $[x']$ and $\lfloor x' \rfloor$ are the points in \mathbb{R}^2 whose coordinates are given by the greatest and least integer parts of the coordinates of x' , respectively. We denote by $SO(3)$, the set of proper rotations, that is

$$SO(3) := \{R \in \mathbb{R}^{3 \times 3} : R^T R = \text{Id and } \det R = 1\}.$$

Given a matrix $M \in \mathbb{R}^{3 \times 3}$, M' stands for 3×2 submatrix of M given by its first two columns. For every $M \in \mathbb{R}^{n \times n}$, $\text{sym } M$ is the $n \times n$ symmetrized matrix defined as

$$\text{sym } M := \frac{M + M^T}{2}.$$

We adopt the convention that C designates a generic constant, whose value may change from expression to expression in the same discussion.

1.2 The Direct Method of the Calculus of Variations and Γ -Convergence

In this section, we give a brief introduction to the direct method of the calculus of variations, Γ -convergence and their basic properties motivated by the works in Chapter 2 and Chapter 3. Let (X, d) be a metric space and let $f : X \rightarrow \overline{\mathbb{R}}$ be a function not identically equal to ∞ , where $\overline{\mathbb{R}}$ is the extended real line, $[-\infty, +\infty]$. The direct method provides conditions on X and f to ensure the existence of a minimum point for f . Tonelli's direct method may be summarized in four steps:

Step 1: Consider a minimizing sequence $\{u_n\} \subset X$, that is, a sequence such that

$$\lim_{n \rightarrow \infty} f(u_n) = \inf_{u \in X} f.$$

Step 2: Prove that $\{u_n\}$ admits a subsequence $\{u_{n_j}\}$ that converges with respect to some (possibly weaker) topology τ to some point $u_0 \in X$.

Step 3: Establish the sequential lower semi-continuity of f with respect to τ .

Step 4: In view of Steps 1-3, conclude that u_0 is a minimum of f because

$$\inf_{u \in X} f = \lim_{n \rightarrow \infty} f(u_n) = \lim_{j \rightarrow \infty} f(u_{n_j}) \geq f(u_0) \geq \inf_{u \in X} f.$$

We now turn our attention to describe the behavior of a family of minimization problems depend-

ing on a parameter, for example,

$$\inf\{f_h(u) : u \in X_h\},$$

for $h > 0$. The goal is to approximate these problems by using a limit theory as $h \rightarrow 0$ leading to an “effective energy” f , with the limiting problems described by

$$\min\{f(u) : u \in X\}.$$

A suitable notion of convergence for the family of functionals f_h so that the limiting functional may be treated using the direct method, as outlined above, is Γ -convergence. Below we briefly recall the principal notions and results but a more detailed explanation can be found in [12, 13, 32]. Our exposition follows closely that of Braides [13] as the main ideas presented there are very transparent and understandable.

The Γ -convergence introduced by De Giorgi and Franzoni [33] is designed to address the convergence of minimum problems: it may be convenient in many situations to study the asymptotic behavior of a family of problems

$$m_h = \min\{f_h(x) : x \in X_h\} \tag{1.1}$$

not through the study of the properties of the solutions x_h , but by defining a limit energy f_0 such that, as $h \rightarrow 0$, the problem

$$m_0 = \min\{f_0 : x \in X_0\} \tag{1.2}$$

is a ‘good approximation’ of the previous one; *i.e.* $m_h \rightarrow m_0$ and $x_h \rightarrow x_0$, where x_0 is itself a solution of m_0 . This latter requirement might involve the extraction of a subsequence if the ‘target’ minimum problem admits more than a solution. Of course, in order to make this procedure a sense, we required a *equi-coerciveness* property for the energies f_h ; *i.e.*, that we may find a pre-compact *minimizing sequence* (that is, $f_h(x_h) \leq \inf f_h + o(1)$) such that the convergence $x_h \rightarrow x_0$ can take place.

Then, the natural notion of the Γ -limit f_0 of f_h , with respect to a topology X_0 is given by the following two conditions:

(i) *liminf inequality*: for every $x \in X_0$ and for every $x_h \rightarrow x$ we have

$$f_0(x) \leq \liminf_{h \rightarrow 0} f_h(x_h). \tag{1.3}$$

In other words, f_0 is a *lower bound* for the sequence f_h , in the sense that $f_0(x) \leq f_h(x_h) + o(1)$, whenever $x_h \rightarrow x$. If the family f_h is equi-coercive, then this condition immediately implies one inequality for the minimization problems: if (x_h) is a minimizing sequence and

(upon subsequences) $x_h \rightarrow x_0$ then

$$\inf f_0 \leq f_0(x_0) \leq \liminf_{h \rightarrow 0} f_h(x_h) = \liminf_{h \rightarrow 0} \inf f_h \quad (1.4)$$

(ii) *limsup inequality or existence of a recovery sequence* : for every $x \in X_0$ we can find a sequence $\bar{x}_h \rightarrow x$ such that

$$f_0(x) \geq \limsup_{h \rightarrow 0} f_h(\bar{x}_h). \quad (1.5)$$

Note that if (i) and (ii) hold then in fact $f_0(x) = \lim_{h \rightarrow 0} f_h(\bar{x}_h)$, so that the lower bound is sharp. From (1.5), we get in particular that $f_0(x) \geq \limsup_{h \rightarrow 0} \inf f_h$, and since this holds for all x , we conclude that

$$\inf f_0 \geq \limsup_{h \rightarrow 0} \inf f_h. \quad (1.6)$$

An f_0 satisfying (1.5) is an *upper bound* for the sequence (f_h) and its computation is usually related to an *ansatz* leading to the construction of the sequence \bar{x}_h .

From the two inequalities (1.3) and (1.6) we obtain the convergence of the infima m_h in (1.1) to the minimum m_0 in (1.2). Not only that: we also obtain that every cluster point of a minimizing sequence is a minimum point for f_0 . This is the *fundamental theorem of Γ -convergence*, that is summarized by the implication

Γ -convergence + equi-coerciveness \implies convergence of minimum problems.

A hidden element in the procedure of the computation of a Γ -limit is the choice of the right notion of convergence $x_h \rightarrow x$. This is actually one of the main issues in the problem: a convergence is not given beforehand and should be chosen in such a way that it implies the equi-coerciveness of the family f_h . The choice of a weaker convergence, with many converging sequences, makes this requirement easier to fulfill, but at the same time makes the liminf inequality more difficult to hold. In the following, we will not insist on the motivation of the choice of the convergence, that in most cases will be a strong L^p -convergence (the choice of a separable metric space makes life easier). The reader is anyhow advised that this is one of the main points of the Γ -convergence approach. Another related issue is that of the correct energy scaling. In fact, in many cases the given functionals f_h will not give rise to an equi-coercive family with respect to a meaningful convergence, but the right scaled functionals, e.g., $h^{-\alpha} f_h$, will turn out to better describe the behaviour of minimum problems. The correct scaling is again usually part of the problem.

Applications of Γ -convergence to partial differential equations can be generally related to the

behaviour of the Euler-Lagrange equations of some integral energy. The prototype of such problems can be rewritten as

$$m_h = \inf \left\{ \int_{\Omega} f_h(x, Du) dx - \int_{\Omega} \langle g, u \rangle dx : u = \varphi \text{ on } \partial\Omega \right\}. \quad (1.7)$$

1.2.1 Definition and properties of Γ -convergence

We have seen at the beginning of Section 1.2 how a definition of Γ -convergence can be given in terms of properties of the functions along converging sequences. That one will be the definition, we will normally use. For the sake of completeness, we give a more general definition of Γ -convergence, following Braides [12] or Dal Maso [32] for a family of functions $f_h : X \rightarrow [-\infty, \infty]$ defined on a *topological space* X . In that case we say that f_h Γ -converges to $f : X \rightarrow [-\infty, \infty]$ at $x \in X$ as $h \rightarrow 0$ if we have

$$\begin{aligned} f(x) &= \sup_{U \in \mathcal{N}(x)} \liminf_{h \rightarrow 0} \inf_{y \in U} f_h(y) \left(= \sup_{U \in \mathcal{N}(x)} \sup_{0 < \rho} \inf_{h < \rho} \inf_{y \in U} f_h(y) \right) \\ &= \sup_{U \in \mathcal{N}(x)} \limsup_{h \rightarrow 0} \inf_{y \in U} f_h(y) \left(= \sup_{U \in \mathcal{N}(x)} \inf_{0 < \rho} \sup_{h < \rho} \inf_{y \in U} f_h(y) \right), \end{aligned} \quad (1.8)$$

where $\mathcal{N}(x)$ denotes the family of all neighbourhoods of x in X . In this case, we say that $f(x)$ is the Γ -limit of f_h at x and we write

$$f(x) = \Gamma - \lim_{h \rightarrow 0} f_h(x). \quad (1.9)$$

If (1.9) holds for all $x \in X$ then we say that f_h Γ -converges to f (on the whole X). Note that we sometime will consider families of functionals $f_h : X_h \rightarrow [-\infty, \infty]$, where the domain may depend on h . In this case, it is understood that we identify such functionals with

$$\tilde{f}_h(x) = \begin{cases} f_h & \text{if } x \in X_h \\ +\infty & \text{if } x \in X \setminus X_h, \end{cases}$$

where X is a space containing all X_h where the convergences takes place.

THEOREM 1.1. (see [13]) (equivalent characterizations of Γ -convergence) *Let X be a metric space and let $f_h, f : X \rightarrow [-\infty, \infty]$. Then the Γ -convergence of f_h to f , in the sense of the definition given above, is equivalent to any of the following conditions*

(a) we have

$$f(x) = \inf \left\{ \liminf_{h \rightarrow 0} f_h(x_h) : x_h \rightarrow x \right\} = \inf \left\{ \limsup_{h \rightarrow 0} f_h(x_h) : x_h \rightarrow x \right\}; \quad (1.10)$$

(b) we have

$$f(x) = \min \left\{ \liminf_{h \rightarrow 0} f_h(x_h) : x_h \rightarrow x \right\} = \min \left\{ \limsup_{h \rightarrow 0} f_h(x_h) : x_h \rightarrow x \right\}; \quad (1.11)$$

(c) (sequential Γ -convergence) we have

(i) (**liminf inequality**) for every sequence (x_h) converging to x

$$f(x) \leq \liminf_{h \rightarrow 0} f_h(x_h); \quad (1.12)$$

(ii) (**limsup inequality**) there exist a sequence (x_h) converging to x such that

$$f(x) \geq \limsup_{h \rightarrow 0} f_h(x_h); \quad (1.13)$$

(d) the liminf inequality (c)(i) holds and

(ii)' (**existence of a recovery sequence**) there exist a sequence (x_h) converging to x such that

$$f(x) = \lim_{h \rightarrow 0} f_h(x_h). \quad (1.14)$$

(e) the liminf (c)(i) holds and

(ii)" (**approximate limsup inequality**) for all $\eta > 0$ there exists a sequence (x_h) converging to x such that

$$f(x) \geq \limsup_{h \rightarrow 0} f_h(x_h) - \eta. \quad (1.15)$$

Moreover, the Γ -convergence of f_h to f on the whole X is equivalent to

(f) (**limits of minimum problems**) inequality

$$\inf_U f \geq \limsup_{h \rightarrow 0} \inf_U f_h \quad (1.16)$$

holds for all open sets U and inequality

$$\inf_K f \leq \sup \left\{ \liminf_{h \rightarrow 0} \inf_U f_h : U \supset K, U \text{ open} \right\} \quad (1.17)$$

holds for all compact sets K .

Finally, if d denote a distance on X and we have a uniform lower bound $f_h(x) \geq -c(1 + d(x, x_0)^p)$ for some $p > 0$ and $x_0 \in X$, then the Γ -convergence of f_h to f on the whole X is equivalent to

(g) (convergence of Moreau-Yosida transforms) we have

$$\begin{aligned} f(x) &= \sup_{\lambda > 0} \liminf_{h \rightarrow 0} \inf_{y \in X} \{f_h(y) + \lambda d(x, y)^p\} \\ &= \sup_{\lambda > 0} \limsup_{h \rightarrow 0} \inf_{y \in X} \{f_h(y) + \lambda d(x, y)^p\}. \end{aligned} \quad (1.18)$$

Now we recall some of the main properties and results involving Γ -convergence.

THEOREM 1.2. (cf. [13]) (Compactness) Let (X, d) be a separable metric space, and for all $j \in \mathbb{N}$ let $f_j : X \rightarrow \overline{\mathbb{R}}$ be a sequence of functions. Then there exist an increasing sequence of integers (j_k) such that $\Gamma - \lim_k f_{j_k}(x)$ exists for all $x \in X$.

PROPOSITION 1.2.1. (see [12]) (Urysohn property) We have $\Gamma - \lim_j f_j = f$ if and only if for every subsequence (f_{j_k}) there exists a further subsequence which Γ -converges to f .

DEFINITION 1.1. A family $f_h : X \rightarrow \overline{\mathbb{R}}$ is called positively homogeneous of degree $d > 0$ if for all $x \in X$ and $\lambda > 0$ we have $f_h(\lambda x) = \lambda^d f_h(x)$ for all $h > 0$.

PROPOSITION 1.2.2. (cf. [13]) If each element of the family (f_h) is positively homogeneous of degree d (respectively, convex, a quadratic form) then their Γ -limit is f_0 is positively homogeneous of degree d (respectively, convex, a quadratic form).

DEFINITION 1.2. We will say that a sequence $f_h : X \rightarrow \overline{\mathbb{R}}$ is equi-coercive if for all $t \in \mathbb{R}$ there exists a compact set K_t such that $\{f_h \leq t\} \subset K_t$.

THEOREM 1.3. (see [13]) (Fundamental theorem of Γ -convergence) Let (X, d) a metric space and let (f_h) be a equi-coercive family of functions on X , and let $f = \Gamma - \lim_{h \rightarrow 0} f_h$; then

$$\min_X f = \lim_{h \rightarrow 0} \left(\inf_X f_h \right). \quad (1.19)$$

Moreover, if (x_h) is a precompact sequence such that $\lim_{h \rightarrow 0} f_h(x_h) = \lim_{h \rightarrow 0} \inf_X f_h$, then every limit of a subsequence (x_h) is a minimum point for f .

In many cases, without scaling Γ -limit provides a functional with a lot of minimizers. In this case, a further ‘ Γ -limit of higher order’, with a different scaling, may bring more information, as formalized in the following result by Anzellotti and Baldo in [5] (see also [6]).

THEOREM 1.4. (cf. [13]) (Development by Γ -convergence) Let (X, d) now be a metric space. Let $f_h : X \rightarrow \overline{\mathbb{R}}$ be a family of d -equi-coercive functions and let $f^0 = \Gamma(d) - \lim_{h \rightarrow 0} F_h$. Let $m_h = \inf f_h$ and $m_0 = \min F^0$. Suppose that for some $\delta_h > 0$ with $\delta_h \rightarrow 0$ there exists the Γ -limit

$$f^1 = \Gamma(d') - \lim_{h \rightarrow 0} \frac{f_h - m^0}{\delta_h}, \quad (1.20)$$

and that the sequence $f_h^1 = (f_h - m^0)/\delta_h$ is d' -equi-coercive for a metric d' which is not weaker than d . Define $m^1 = \min F^1$ and suppose that $m^1 \neq +\infty$; then we have that

$$m_h = m^0 + \delta_h m^1 + o(\delta_h) \quad (1.21)$$

and from all sequences (x_h) such that $f_h(x_h) - m_h = o(\delta_h)$ (in particular this holds for minimizers, if any) there exists a subsequence converging in (X, d') to a point x which minimizes both f^0 and f^1 .

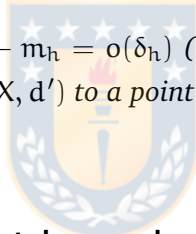

1.3 Thin structures, ferroelectric and nonlinearly hyperelastic model

1.3.1 Thin structures

A thin structure is a three-dimensional object with one preponderant dimension, such as a wire, rod, beam, a combination of wires or two preponderant dimensions such as in thin films, thin plates, shell structures etc. In these structures, some physical phenomena take place that are generally described by variational problems. By starting from 3D models and using asymptotic mathematical methods, one tries to obtain 1D or 2D limit problems describing the physical phenomena in a thin structure. The reduced models are justified by reasons of simplicity and economy, and are also necessary from a numerical point of view. In this thesis, we are interested in ferroelectric problems and in nonlinearly hyperelastic problems in thin structures which are unions of components of a one-dimensional nature.

1.3.2 Ferroelectric model

Ferroelectricity is a property of some materials to have a spontaneous electrical polarization that can be reversed by the application of an external electric field. Hysteresis phenomena appear, so the behavior of these materials is very similar to the one of ferromagnetic materials. Analogously, a Curie temperature T_C appears, too.

The idea of existence of materials which can have stable electric polarization is as old as the study of electrical phenomena. The quest was perhaps opened by S. Gray in the middle of eighteenth century. O. Hevesy is quoted as the creator of term “electret” for this kind of materials in 1885, borrowing the name from magnet, by analogy. T. Iguchi obtained the first electret at the beginning of the 1920s by mixing and heating some inorganic natural materials. In the 1920s, J. Valasek discovered the presence of a hysteresis cycle (and so the first ferroelectric material) in Rochelle salt, a common salt but chemically and crystallographically complex enough. Immediately later, another ferroelectric salt was discovered (KH_2PO_4). Then the study of ferroelectric phenomena using some theoretical models were proposed. In the 1940s, the family of ferroelectric material enlarged, e.g. ferroelectric properties were demonstrated in barium titanate (BaTiO_3) and lead titanate (PbTiO_3). These simple materials opened the way for industrial use of materials with ferroelectric properties and also the modeling of these materials was more intensively studied. Properties of ferroelectric materials are now applied in a wide variety of contexts. In particular, due to the switching effect of hysteresis cycle, thin ferroelectric materials are used in electronic circuits with miniaturized and integrated forms in memory and storage devices as, for instance, radio frequency identification cards (RFID). Moreover, also the ferroelectric tunnel junction (FTJ) seems to offer great opportunities. We refer to [9, 22, 30], about the history and applications of ferroelectric material. Recently, the mathematical modeling (in the static case) of thin structures of ferroelectric materials was studied starting from a non-convex and nonlocal 3D-variational model for the electric polarization. Via an asymptotic process based on dimensional reduction, 2D-variational models for thin films were obtained in [46], and 1D-variational models for thin wires were obtained in [47].

Now, we summarize the essential features of the model that we consider (see also [9, 22, 30, 63, 68, 71, 76]). We do not take into account any deformation of the ferroelectric material. The electric displacement \mathbf{D} is given by $\mathbf{D} = \varepsilon_0 \mathbf{E} + \mathbf{P}$, where $\varepsilon_0 > 0$ is the vacuum permeability, \mathbf{E} is the applied external field, and \mathbf{P} is the spontaneous electric polarization in a ferroelectric body B . Assume that \mathbf{E} is the gradient of a potential ψ , i.e.

$$\mathbf{E} = \mathbf{D}\psi, \tag{1.22}$$

and that the electric field generated by \mathbf{P} derives from a potential $\varphi_{\mathbf{P}}$ satisfying the electrostatic equation

$$\operatorname{div} (-\varepsilon_0 \mathbf{D}\varphi_{\mathbf{P}} + \mathbf{P}) = 0. \quad (1.23)$$

We limit ourselves to the case where no strong electric field has been applied on B , but only a very weak electric field acts on it (e.g. it is the case of iron in the ferromagnetism, before the magnetization, by analogy). Then we can assume that there are not Weiss domains (i.e. regions with different polarization separated by well-defined interfaces), but only transition regions. In this framework, we can assume that the polarization does not generate an electric field outside B . Consequently, equation (1.23) holds true in B , and the boundary conditions

$$\mathbf{P} \cdot \boldsymbol{\nu} = 0, \quad \mathbf{D}\varphi_{\mathbf{P}} \cdot \boldsymbol{\nu} = 0 \quad \text{on } \partial B \quad (1.24)$$

can be added, where $\boldsymbol{\nu}$ denotes the unit outer normal on ∂B .

One assumes that \mathbf{P} minimizes the energy functional

$$\int_B \left(\beta |\operatorname{rot} \mathbf{P}|^2 + |\operatorname{div} \mathbf{P}|^2 + \alpha (|\mathbf{P}|^2 - 1)^2 \right) dx + \int_{\mathbb{R}^3} |\mathbf{D}\psi + \mathbf{D}\varphi_{\mathbf{P}}|^2 dx, \quad (1.25)$$

where α and β are two positive constants independent of the external field and of the temperature. Here, $\int_B (\beta |\operatorname{rot} \mathbf{P}|^2 + |\operatorname{div} \mathbf{P}|^2) dx$ reduces to the classical energy $\int_B |\mathbf{D}\mathbf{P}|^2 dx$ when $\beta = 1$ (see (1.22)), so roughly speaking this term penalizes the spatial variation of \mathbf{P} . The term $\alpha \int_B (|\mathbf{P}|^2 - 1)^2 dx$ obliges $|\mathbf{P}|$ to be near to 1, and it can induce a phase transition of \mathbf{P} . So the body is driven to have regions of uniform polarization separated by thin transition layers. The term $\int_{\mathbb{R}^3} |\mathbf{D}\psi + \mathbf{D}\varphi_{\mathbf{P}}|^2 dx$ is the electrostatic energy. As this last term is concerned, we have

$$\int_{\mathbb{R}^3} |\mathbf{D}\psi + \mathbf{D}\varphi_{\mathbf{P}}|^2 dx = \int_{\mathbb{R}^3} |\mathbf{E}|^2 dx + 2 \int_B \mathbf{D}\psi \cdot \mathbf{D}\varphi_{\mathbf{P}} dx + \int_B |\mathbf{D}\varphi_{\mathbf{P}}|^2 dx, \quad (1.26)$$

thanks to (1.22). On the other hand, using (1.23) and (1.24) give

$$\int_B \mathbf{D}\psi \cdot \mathbf{D}\varphi_{\mathbf{P}} dx = \frac{1}{\varepsilon_0} \int_B \mathbf{D}\psi \cdot \mathbf{P} dx. \quad (1.27)$$

Consequently, inserting (1.26) and (1.27) in (1.25), and remarking that $\int_{\mathbb{R}^3} |\mathbf{E}|^2 dx$ is constant with respect to \mathbf{P} , the energy functional minimized by \mathbf{P} becomes

$$\int_B \left(\beta |\operatorname{rot} \mathbf{P}|^2 + |\operatorname{div} \mathbf{P}|^2 + \alpha (|\mathbf{P}|^2 - 1)^2 \right) dx + \int_B |\mathbf{D}\varphi_{\mathbf{P}}|^2 dx + \frac{2}{\varepsilon_0} \int_B \mathbf{E} \cdot \mathbf{P} dx, \quad (1.28)$$

where $\int_{\mathbb{B}} |\mathbf{D}\varphi_{\mathbf{P}}|^2 dx$ is the electrostatic energy induced by \mathbf{P} , and the external energy $\int_{\mathbb{B}} \mathbf{E} \cdot \mathbf{P} dx$ favors the polarization parallel (but in opposite sense) to \mathbf{E} .

1.3.3 Nonlinearly hyperelastic model

We consider an elastic body that occupies the closure of a bounded, open, connected subset Ω of \mathbb{R}^3 with a sufficiently smooth boundary in the absence of applied forces, henceforth called the reference configuration of the body. Any other configuration that the body might occupy when subjected to applied forces will be defined by means of a deformation, that is, a mapping

$$\Phi : \overline{\Omega} \rightarrow \mathbb{R}^3$$

that is *orientation preserving* (i.e., $\det \nabla \Phi(\mathbf{x}) > 0$ for all $\mathbf{x} \in \overline{\Omega}$) and *injective* on the open set Ω (i.e., no interpenetration of matter occurs). The image $\Phi(\overline{\Omega})$ is called the *deformed configuration* of the body defined by the deformation Φ . “The difference” between a deformed configuration and the reference configuration is given by the *displacement*, which is the vector field defined by

$$\mathbf{u} := \Phi - \mathbf{id},$$

where $\mathbf{id} : \overline{\Omega} \rightarrow \overline{\Omega}$ is the identity map.

We now give the basic definitions and notions of elastic materials and refer to Ciarlet [24] for a more detailed description of the same. Let $\mathbf{T}(\mathbf{x})$ and $\Sigma(\mathbf{x})$ be the first and second Piola-Kirchhoff stress tensor at \mathbf{x} respectively. A material is **elastic** if there exist a function $\mathbf{T}(\mathbf{x}) : \overline{\Omega} \times \mathbb{R}_+^{3 \times 3} \rightarrow \mathbb{R}^{3 \times 3}$ such that

$$\mathbf{T}(\mathbf{x}) := \mathbf{T}^\#(\mathbf{x}, \nabla \Phi(\mathbf{x})), \quad \text{for all } \mathbf{x} \in \overline{\Omega} \subset \mathbb{R}^3.$$

Equivalently, a material is **elastic** if there exists a function $\Sigma^\# : \overline{\Omega} \times \mathbb{R}_+^{3 \times 3} \rightarrow \mathbb{R}^{3 \times 3}$ such that

$$\Sigma(\mathbf{x}) := \Sigma^\#(\mathbf{x}, \nabla \Phi(\mathbf{x})), \quad \text{for all } \mathbf{x} \in \overline{\Omega} \subset \mathbb{R}^3.$$

Either function $\mathbf{T}^\#$ or $\Sigma^\#$ is called the **response function** of the material.

1.3.3.1 Frame-indifference

A *response function* can not be arbitrary, because a general axiom in physics asserts that any “observable quantity” must be independent of the particular orthogonal basis in which it is computed. This property, which must be satisfied by all elastic materials, is called the **axiom of material frame-indifference**. The following theorem translates this axiom in terms of the response function of the material.

THEOREM 1.5. [24, Section 3.3.] *An elastic material satisfies the axiom of material frame-indifference if and only if*

$$\mathbf{T}^\#(\mathbf{x}, \mathbf{Q}\mathbf{F}) = \mathbf{Q}\mathbf{T}^\#(\mathbf{x}, \mathbf{F}) \quad \text{for all } \mathbf{x} \in \overline{\Omega} \text{ and } \mathbf{Q} \in \text{SO}(3) \quad \text{and} \quad \mathbf{F} \in \mathbb{R}_+^{3 \times 3},$$

or equivalently,

$$\Sigma^\#(\mathbf{x}, \mathbf{Q}\mathbf{F}) = \Sigma^\#(\mathbf{x}, \mathbf{F}) \quad \text{for all } \mathbf{x} \in \overline{\Omega} \text{ and } \mathbf{Q} \in \text{SO}(3) \quad \text{and} \quad \mathbf{F} \in \mathbb{R}_+^{3 \times 3}.$$

This axiom restricts the form of the response function. We now examine how its form can be further restricted by other properties that a given material may possess.

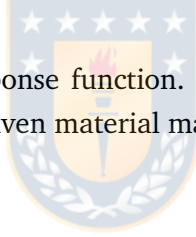

1.3.3.2 Isotropic material

An elastic material is **isotropic** at a point \mathbf{x} of the reference configuration if the response of the material “is the same in all directions”. An elastic material occupying a reference configuration $\overline{\Omega}$ is **isotropic** if it is isotropic at all points of $\overline{\Omega}$. The following theorem gives a characterization of the response function of an isotropic elastic material:

THEOREM 1.6. [24, Section 3.4.] *An elastic material occupying a reference configuration $\overline{\Omega}$ is isotropic if and only if*

$$\mathbf{T}^\#(\mathbf{x}, \mathbf{F}\mathbf{Q}) = \mathbf{T}^\#(\mathbf{x}, \mathbf{F})\mathbf{Q} \quad \text{for all } \mathbf{x} \in \overline{\Omega} \text{ and } \mathbf{Q} \in \text{SO}(3) \quad \text{and} \quad \mathbf{F} \in \mathbb{R}_+^{3 \times 3},$$

equivalently,

$$\Sigma^\#(\mathbf{x}, \mathbf{F}\mathbf{Q}) = \mathbf{Q}^\top \Sigma^\#(\mathbf{x}, \mathbf{F})\mathbf{Q} \quad \text{for all } \mathbf{x} \in \overline{\Omega} \text{ and } \mathbf{Q} \in \text{SO}(3) \quad \text{and} \quad \mathbf{F} \in \mathbb{R}_+^{3 \times 3}.$$

1.3.3.3 Natural state

The response function of an elastic material can be further restricted if its reference configuration is a *natural state*, according to the following definition: A reference configuration $\bar{\Omega}$ is called **natural state**, or equivalently is said to be **stress-free** (see [24, Section 3.6.]), if

$$\mathbf{T}^\#(\mathbf{x}, \mathbf{I}) = 0 \quad \text{for all } \mathbf{x} \in \bar{\Omega},$$

or equivalently, if and only if

$$\Sigma^\#(\mathbf{x}, \mathbf{I}) = 0 \quad \text{for all } \mathbf{x} \in \bar{\Omega}.$$

1.3.3.4 The equations of nonlinear three-dimensional elasticity

Assuming that the constituting material has known response function given by $\mathbf{T}^\#$ or by $\Sigma^\#$ and that the body is held fixed on $\Gamma_0 := \partial\Omega \setminus \Gamma_1$, one can deduce combining the equations of equilibrium given in [24, Theorem 2.6-1.] with the constitute equations of the material seen above (frame-indifference, isotropic, heterogeneous and natural state) that the deformation arising in the body in response to the applied forces of densities \mathbf{f} and \mathbf{g} satisfies the nonlinear boundary value problem:

$$\begin{aligned} -\operatorname{div} \mathbf{T}(\mathbf{x}) &= \mathbf{f}(\mathbf{x}), & \mathbf{x} \in \Omega, \\ \Phi(\mathbf{x}) &= \mathbf{x}, & \mathbf{x} \in \Gamma_0, \\ \mathbf{T}(\mathbf{x})\mathbf{n}(\mathbf{x}) &= \mathbf{g}(\mathbf{x}), & \mathbf{x} \in \Gamma_1, \end{aligned} \tag{1.29}$$

where Γ_1 is a da-measurable subset of the boundary of Ω , $\Gamma_0 = \partial\Omega \setminus \Gamma_1$,

$$\mathbf{T}(\mathbf{x}) = \mathbf{T}^\#(\mathbf{x}, \nabla\Phi(\mathbf{x})) = \nabla\Phi(\mathbf{x})\Sigma^\#(\mathbf{x}, \nabla\Phi(\mathbf{x})) \quad \text{for all } \mathbf{x} \in \bar{\Omega}.$$

1.3.3.5 Hyperelastic material

An elastic material is **hyperelastic** if there exist a function $W : \bar{\Omega} \rightarrow \mathbb{R}_+^{3 \times 3} \rightarrow \mathbb{R}$, called the **stored energy function**, such that its response function $\mathbf{T}^\#$ can be fully reconstructed from W by means of the relation

$$\mathbf{T}^\#(\mathbf{x}, \mathbf{F}) = \frac{\partial W}{\partial \mathbf{F}}(\mathbf{x}, \mathbf{F}) \quad \text{for all } (\mathbf{x}, \mathbf{F}) \in \bar{\Omega} \times \mathbb{R}_+^{3 \times 3},$$

where $\frac{\partial W}{\partial \mathbf{F}}$ denotes the Fréchet derivative of W with respect to the variable \mathbf{F} . In other words, at each $\mathbf{x} \in \overline{\Omega}$, $\frac{\partial W}{\partial \mathbf{F}}(\mathbf{x}, \mathbf{F})$ is the unique matrix in $\mathbb{R}^{3 \times 3}$ that satisfies

$$W(\mathbf{x}, \mathbf{F} + \mathbf{H}) = W(\mathbf{x}, \mathbf{F}) + \frac{\partial W}{\partial \mathbf{F}}(\mathbf{x}, \mathbf{F}) : \mathbf{H} + \mathbf{o}_{\mathbf{x}}(|\mathbf{H}|)$$

for all $\mathbf{F} \in \mathbb{R}_+^{3 \times 3}$ and $\mathbf{H} \in \mathbb{R}^{3 \times 3}$ (a detailed study of hyperelastic materials can be found in e.g. [24, Chap. 4]).

John Ball [8] has shown that the *minimization problem* formally associated with the equations of nonlinear three-dimensional elasticity (see (1.29)) when the material constituting the body is *hyperelastic* has solutions if the function W satisfies certain physically realistic conditions of *polyconvexity*, *coerciveness*, and *growth*.

The major interest of hyperelastic materials is that, for such materials, the equations of nonlinear three-dimensional elasticity are, at least formally, the Euler equation associated with a minimization problem (this property only holds formally because, in general, the solution to the minimization problem does not have the regularity needed to properly establish the Euler equation associated with the minimization problem). To see this, consider first the equations of nonlinear three-dimensional elasticity (see (1.29)), where, for simplicity, we have assumed that the applied forces do not depend on the unknown deformation Φ .

A weak solution Φ to the boundary problem (1.29) is then the solution to the following variational problema, also known as the **principle of virtual works**:

$$\int_{\Omega} \mathbf{T}^{\#}(\cdot, \nabla \Phi) : \nabla \mathbf{v} \, dx = \int_{\Omega} \mathbf{f} \cdot \mathbf{v} \, dx + \int_{\Gamma_1} \mathbf{g} \cdot \mathbf{v} \, da \quad (1.30)$$

for all smooth enough vector fields $\mathbf{v} : \overline{\Omega} \rightarrow \mathbb{R}^3$ such that $\mathbf{v} = 0$ on Γ_0 . If the material is hyperelastic, then $\mathbf{T}^{\#}(\mathbf{x}, \nabla \Phi(\mathbf{x})) = \frac{\partial W}{\partial \mathbf{F}}(\mathbf{x}, \nabla \Phi(\mathbf{x}))$, and the above equation can be written as

$$J'(\Phi)\mathbf{v} = 0,$$

where J' is the Fréchet derivative of the functional J defined by

$$J(\Psi) := \int_{\Omega} W(\mathbf{x}, \nabla \Psi(\mathbf{x})) \, dx - \int_{\Omega} \mathbf{f} \cdot \Psi \, dx - \int_{\Gamma_1} \mathbf{g} \cdot \Psi \, da, \quad (1.31)$$

for all smooth enough vector fields $\Psi : \overline{\Omega} \rightarrow \mathbb{R}^3$ such that $\Psi = \mathbf{id}$ on Γ_0 . The functional J is called the **total energy**.

Therefore the variational equations associated with the equations of nonlinear three-dimensional elasticity are, at least formally, the Euler equations associated with the minimization problem

$$J(\Phi) = \min_{\Psi \in \mathcal{M}} J(\Psi),$$

where \mathcal{M} is an appropriate set of all *admissible deformations* $\Psi : \Omega \rightarrow \mathbb{R}^3$.

The first term in equation (1.31)

$$E(\Psi) := \int_{\Omega} W(x, \nabla \Psi(x)) \, dx \tag{1.32}$$

is called the elastic energy for a three-dimensional body Ω made of the same nonlinearly hyperelastic material which satisfies the axiom of material frame-indifference and is a natural state, *i.e.* for all $x \in \Omega$, we have $W(x, \mathbf{R}\mathbf{F}) = W(x, \mathbf{F})$ and $W(x, \mathbf{I}) = 0$ for all $\mathbf{F} \in \mathbb{R}^{3 \times 3}$, $\mathbf{R} \in \text{SO}(3)$.



PART II

T-junction of ferroelectric wires



T-junction of ferroelectric wires

L. Carbone, A. Gaudiello, P. Hernández-Llanos, T-junction of ferroelectric wires, *published (online and printed versions) in ESAIM: Mathematical Modelling and Numerical Analysis*.

DOI: <https://doi.org/10.1051/m2an/2020001>.

Abstract. In this chapter, starting from a non-convex and nonlocal 3D variational mathematical model for the electric polarization in a ferroelectric material, and using an asymptotic process based on dimensional reduction, we analyze junction phenomena for two orthogonal joined ferroelectric wires. Depending on the initial boundary conditions, we get several limit problems.

Keywords: electric polarization, nonlocal problems, optimal control, wire, junctions.

2010 AMS subject classifications: 35Q61; 78A25; 49J20.

2.1 Introduction

In this paper, starting from a non-convex and nonlocal 3D variational mathematical model for the electric polarization in a ferroelectric material, and using an asymptotic process based on dimensional reduction, we analyze junction phenomena, from an energetic point of view, for two T-joined ferroelectric wires. Depending on the initial boundary conditions, we get several limit problems. We refer to [9], [22], [30], [63], [68], [71], and [76] (see also the introduction in [16]) about general history, applications, and mathematical modeling of the electric polarization in ferroelectric structures.

Let $\{h_n\}_{n \in \mathbb{N}} \subset]0, 1[$ be a sequence such that

$$\lim_n h_n = 0.$$

For every $n \in \mathbb{N}$, set (see Figure 3.1)

$$\Omega_n^a = h_n]-\frac{1}{2}, \frac{1}{2}[^2 \times]0, 1[, \quad \Omega_n^b =]-\frac{1}{2}, \frac{1}{2}[\times h_n (]-\frac{1}{2}, \frac{1}{2}[\times]-1, 0[), \quad \Omega_n = \Omega_n^a \cup \Omega_n^b.$$

The multidomain Ω_n models a ferroelectric structure consisting of two joined orthogonal parallelepipeds Ω_n^a and Ω_n^b . The first parallelepiped has constant height along the direction x_3 , the second one has constant height along the direction x_1 , while both of them have a small cross section of area h_n^2 and are joined by the small surface $h_n]-\frac{1}{2}, \frac{1}{2}[^2 \times \{0\}$. Several energetic approaches can be consid-

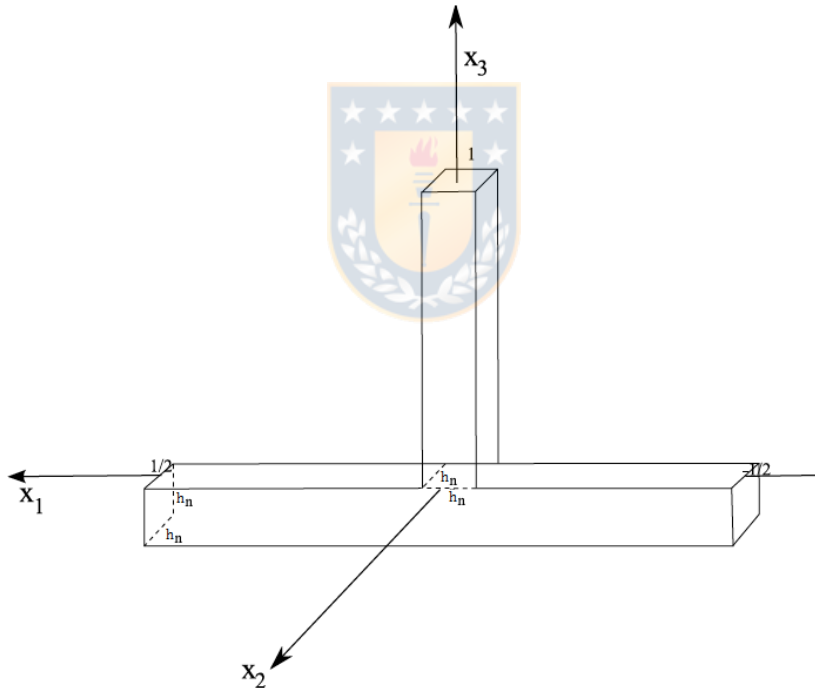

Figure 2.1 The set Ω_n .

ered. We begin with a standard choice for the functional representing the energy. Precisely, consider the following non-convex and non-local energy associated with Ω_n

$$\mathcal{E}_n : \mathbf{P} \in \left(H^1(\Omega_n) \right)^3 \rightarrow \int_{\Omega_n} \left(|\mathbf{D} \mathbf{P}|^2 + \alpha \left(|\mathbf{P}|^2 - 1 \right)^2 + |\mathbf{D} \varphi_{\mathbf{P}}|^2 + \mathbf{F}_n \cdot \mathbf{P} \right) dx, \quad (2.1)$$

where α is a positive constant, $\mathbf{F}_n \in (L^2(\Omega_n))^3$, \cdot denotes the inner product in \mathbb{R}^3 , and $\varphi_{\mathbf{P}}$ is the unique solution, up to an additive constant, to

$$\min \left\{ \int_{\Omega_n} \left(-\frac{1}{2} |\mathbf{D}\varphi|^2 + \mathbf{P} \cdot \mathbf{D}\varphi \right) dx : \varphi \in H^1(\Omega_n) \right\}, \quad (2.2)$$

or alternatively $\varphi_{\mathbf{P}}$ is the unique solution to the following problem

$$\min \left\{ \int_{\Omega_n} \left(-\frac{1}{2} |\mathbf{D}\varphi|^2 + \mathbf{P} \cdot \mathbf{D}\varphi \right) dx : \varphi \in H_0^1(\Omega_n) \right\}. \quad (2.3)$$

Note that in (2.2) and in (2.3) the vacuum permeability constant is assumed equal to 1.

The direct method of calculus of variations ensures that the following problems

$$\min \left\{ \mathcal{E}_n(\mathbf{P}) : \mathbf{P} \in (H^1(\Omega_n))^3 \right\}, \quad (2.4)$$

$$\min \left\{ \mathcal{E}_n(\mathbf{P}) : \mathbf{P} \in (H^1(\Omega_n))^3, \mathbf{P} \cdot \boldsymbol{\nu} = 0 \text{ on } \partial\Omega_n \right\}, \quad (2.5)$$

and

$$\min \left\{ \mathcal{E}_n(\mathbf{P}) : \mathbf{P} \in (H^1(\Omega_n))^3, \mathbf{P} // \mathbf{e}_3 \text{ on } \partial\Omega_n \right\}, \quad (2.6)$$

admit solutions, where $\boldsymbol{\nu}$ denotes the unit outer normal on $\partial\Omega_n$, $\mathbf{e}_3 = (0, 0, 1)$, and $//$ is the symbol of parallelism.

Note that (2.4), (2.5), and (2.6) are optimal control problems.

With respect to the conditions on $\varphi_{\mathbf{P}}$, we note that considering minimization problem (2.2) provides

$$\begin{cases} \operatorname{div} (-\mathbf{D}\varphi_{\mathbf{P}} + \mathbf{P}) = 0, & \text{in } \Omega_n, \\ (-\mathbf{D}\varphi_{\mathbf{P}} + \mathbf{P}) \cdot \boldsymbol{\nu} = 0, & \text{on } \partial\Omega_n, \end{cases} \quad (2.7)$$

and so the classical boundary flow balance condition, while minimization problem (2.3) provides

$$\begin{cases} \operatorname{div} (-\mathbf{D}\varphi_{\mathbf{P}} + \mathbf{P}) = 0, & \text{in } \Omega_n, \\ \varphi_{\mathbf{P}} = 0, & \text{on } \partial\Omega_n, \end{cases} \quad (2.8)$$

and so the classical boundary condition of "grounded domain".

We precise that our modeling is restricted to the cases where the external field \mathbf{F}_n is weak with respect to the intensity of the intrinsic polarization \mathbf{P} . So, in our choice of energetic functional, we can omit to take into account formation of Weiss domains and walls, but we admit only transition regions. Moreover, considering minimization problem (2.5) entails the action of a very weak external field \mathbf{F}_n on a body which was not previously polarized (see also introduction in [16]). Considering minimization problem (2.6) entails the action of an external field \mathbf{F}_n on a body previously polarized along an assigned direction. The external field is not strong enough to change the orientation of the polarization on the boundary. Eventually, considering minimization problem (2.4) entails the action of a stronger electric field \mathbf{F}_n .

The goal of this paper is to study the asymptotic behavior, as n to ∞ , of these problems. To this aim, the external field \mathbf{F}_n is rescaled on

$$\Omega^a \cup \Omega^b = \left(]-\frac{1}{2}, \frac{1}{2}[\times]0, 1[\right) \cup \left(]-\frac{1}{2}, \frac{1}{2}[\times]-1, 0[\right)$$

((see (2.18)) and the rescaled field is assumed to converge to (f^a, f^b) weakly in $(L^2(\Omega^a))^3 \times (L^2(\Omega^b))^3$ (see (2.30)). Moreover, let

$$\begin{aligned} E^a : q^a \in \left(H^1(]0, 1[) \right)^3 &\rightarrow \int_0^1 \left(\left| \frac{dq^a}{dx_3} \right|^2 + \alpha (|q^a|^2 - 1)^2 + \eta (|q_1^a|^2 + |q_2^a|^2) + |q_3^a|^2 \right) dx_3 \\ &+ \int_0^1 \left(\int_{]-\frac{1}{2}, \frac{1}{2}[} f^a dx_1 dx_2 \cdot q^a \right) dx_3, \end{aligned}$$

$$\begin{aligned} E_l^b : q^b \in \left(H^1 \left(]-\frac{1}{2}, 0[\right) \right)^3 &\rightarrow \int_{-\frac{1}{2}}^0 \left(\left| \frac{dq^b}{dx_1} \right|^2 + \alpha (|q^b|^2 - 1)^2 + |q_1^b|^2 + \eta (|q_2^b|^2 + |q_3^b|^2) \right) dx_1 \\ &+ \int_{-\frac{1}{2}}^0 \left(\int_{]-\frac{1}{2}, \frac{1}{2}[\times]-1, 0[} f^b dx_2 dx_3 \cdot q^b \right) dx_1, \end{aligned}$$

and

$$\begin{aligned} E_r^b : q^b \in \left(H^1 \left(\left[0, \frac{1}{2} \right] \right) \right)^3 &\rightarrow \int_0^{\frac{1}{2}} \left(\left| \frac{dq^b}{dx_1} \right|^2 + \alpha (|q^b|^2 - 1)^2 + |q_1^b|^2 + \eta (|q_2^b|^2 + |q_3^b|^2) \right) dx_1 \\ &+ \int_0^{\frac{1}{2}} \left(\int_{]-\frac{1}{2}, \frac{1}{2}[\times]-1, 0[} f^b dx_2 dx_3 \cdot q^b \right) dx_1, \end{aligned}$$

where η is the constant defined by

$$\eta = \int_{]-\frac{1}{2}, \frac{1}{2}[}^2 |\text{Dr}|^2 dy dz, \quad (2.9)$$

r being the unique solution to a suitable variational problem (see (2.31)).

As far as the first problem (2.4) with the constraint (2.2) is concerned, we prove that

$$\begin{aligned} \liminf_n \left\{ \frac{1}{|\Omega_n|} \mathcal{E}_n(\mathbf{P}) : \mathbf{P} \in \left(H^1(\Omega_n) \right)^3 \right\} &= \frac{1}{2} \min \left\{ E^\alpha(q^\alpha) + E_l^b(q^b) + E_r^b(q^b) : \right. \\ &\left. (q^\alpha, q^b) \in \left(H^1(]0, 1[) \right)^3 \times \left(H^1\left(]-\frac{1}{2}, \frac{1}{2}[\right) \right)^3, \quad q^\alpha(0) = q^b(0) \right\}. \end{aligned} \quad (2.10)$$

More precisely, (see Theorem 2.1) we study the asymptotic behavior of the rescaled polarization. On the vertical wire we obtain a limit polarization $p^\alpha = (p_1^\alpha, p_2^\alpha, p_3^\alpha)$ independent of (x_1, x_2) . On the horizontal wire we obtain a limit polarization $p^b = (p_1^b, p_2^b, p_3^b)$, independent of (x_2, x_3) . Moreover,

$$p^\alpha(0) = p^b(0)$$

and (p^α, p^b) is a solution to the 1-dimensional vector valued problem in the right-hand side of (2.10).

As far as the second problem (2.5) with the constraint (2.2) is concerned, we prove that

$$\begin{aligned} \liminf_n \left\{ \frac{1}{|\Omega_n|} \mathcal{E}_n(\mathbf{P}) : \mathbf{P} \in \left(H^1(\Omega_n) \right)^3 : \mathbf{P} \cdot \nu = 0 \text{ on } \partial\Omega_n \right\} \\ = \frac{1}{2} \min \left\{ E^\alpha(0, 0, q_3^\alpha) : q_3^\alpha \in H_0^1(]0, 1[) \right\} \\ + \frac{1}{2} \min \left\{ E_l^b(q_1^b, 0, 0) : q_1^b \in H_0^1\left(]-\frac{1}{2}, 0[\right) \right\} + \frac{1}{2} \min \left\{ E_r^b(q_1^b, 0, 0) : q_1^b \in H_0^1\left(]0, \frac{1}{2}[\right) \right\}. \end{aligned} \quad (2.11)$$

More precisely, (see Theorem 2.2) on the vertical wire we obtain a limit polarization $(0, 0, p_3^\alpha)$ where p_3^α is independent of (x_1, x_2) and is a solution to the first 1-dimensional scalar problem in the right-hand side of (2.11). On the first half of the horizontal wire we obtain a limit polarization $(p_{1,l}^b, 0, 0)$ where $p_{1,l}^b$ is independent of (x_2, x_3) and it is a solution to the second 1-dimensional scalar problem in the right-hand side of (2.11). On the second half of the horizontal wire we obtain a limit polarization $(p_{1,r}^b, 0, 0)$ where $p_{1,r}^b$ it is independent of (x_2, x_3) and is a solution to the third 1-dimensional scalar problem in the right-hand side of (2.11). Then, in this case we obtain three uncoupled problems.

As the third problem (2.6) with the constraint (2.2) is concerned, we prove that

$$\begin{aligned} & \lim_n \min \left\{ \frac{1}{|\Omega_n|} \mathcal{E}_n(\mathbf{P}) : \mathbf{P} \in \left(H^1(\Omega_n) \right)^3 : \mathbf{P} // \mathbf{e}_3 \text{ on } \partial\Omega_n \right\} \\ &= \frac{1}{2} \min \left\{ E^a(0, 0, q_3^a) + E_l^b(0, 0, q_3^b) + E_r^b(0, 0, q_3^b) : \right. \\ & \left. (q_3^a, q_3^b) \in H^1(]0, 1[) \times H^1\left(]-\frac{1}{2}, \frac{1}{2}[\right), q_3^a(0) = q_3^b(0) \right\}. \end{aligned} \quad (2.12)$$

More precisely, (see Theorem 2.3) on the vertical wire we obtain a limit polarization $(0, 0, p_3^a)$ where p_3^a is independent of (x_1, x_2) . On the horizontal wire we obtain a limit polarization $(0, 0, p_3^b)$ where p_3^b is independent of (x_2, x_3) . Moreover, $p_3^a(0) = p_3^b(0)$ and the couple (p_3^a, p_3^b) is a solution to the 1-dimensional scalar problem in the right-hand side of (2.12).

We point out that all the limit problems remained non-convex, but the nonlocal behavior disappeared, i.e. the limit problem is not longer a control problem. Indeed, the nonlocal control term

$$\int_{\Omega_n} |D\varphi_{\mathbf{P}}|^2 dx \quad (2.13)$$

produce the following weights in the limit minimization problems

$$\begin{aligned} & \int_0^1 \left(\eta \left(|q_1^a|^2 + |q_2^a|^2 \right) + |q_3^a|^2 \right) dx_3, \\ & \int_{-\frac{1}{2}}^0 \left(|q_1^b|^2 + \eta \left(|q_2^b|^2 + |q_3^b|^2 \right) \right) dx_1, \quad \int_0^{\frac{1}{2}} \left(|q_1^b|^2 + \eta \left(|q_2^b|^2 + |q_3^b|^2 \right) \right) dx_1. \end{aligned}$$

We just notice that the asymptotic behavior of problem (2.4) under the boundary condition $\mathbf{P} // (1, 0, 0)$ or $\mathbf{P} // (0, 1, 0)$ on $\partial\Omega_n$ can be treated similarly to the asymptotic behavior of problem (2.6). This easy task is left to an interested reader.

If we associate problems (2.4), (2.5), and (2.6) with the constraint (2.3), we prove that the non-local term (2.13) does not give any contribution to the limit problem.

Another very significant choice for an energetic approach consists in explicitly considering the energetic contribution for the polarization field given by the divergence term and the curl term. Consider

the following non-convex and non-local energy associated with Ω_n

$$\begin{aligned} \mathcal{S}_n : \mathbf{P} \in (H^1(\Omega_n))^3 &\rightarrow \\ \int_{\Omega_n} &\left(\beta |\operatorname{rot} \mathbf{P}|^2 + |\operatorname{div} \mathbf{P}|^2 + \alpha (|\mathbf{P}|^2 - 1)^2 + |\operatorname{D}\varphi_{\mathbf{P}}|^2 + \mathbf{F}_n \cdot \mathbf{P} \right) dx, \end{aligned} \quad (2.14)$$

where α and β are two positive constant and $\varphi_{\mathbf{P}}$ is a solution to (2.2) or alternatively to (2.3). For sake of simplicity, we limit ourselves to the cases where there is an equivalence between the term $\|\operatorname{D}\mathbf{P}\|_{(L^2(\Omega_n))^9}^2$ and the term $\|\operatorname{rot} \mathbf{P}\|_{(L^2(\Omega_n))^3}^2 + \|\operatorname{div} \mathbf{P}\|_{L^2(\Omega_n)}^2$. This equivalence is assured by the boundary conditions on $\partial\Omega_n$

$$\mathbf{P} \cdot \boldsymbol{\nu} = 0 \text{ or } \mathbf{P} \wedge \boldsymbol{\nu} = 0,$$

with \wedge denoting the cross product in \mathbb{R}^3 (for instance, see [29]). Then, the direct method of calculus of variations ensures that also the following problem

$$\min \left\{ \mathcal{S}_n(\mathbf{P}) : \mathbf{P} \in (H^1(\Omega_n))^3, \mathbf{P} \cdot \boldsymbol{\nu} = 0 \text{ on } \partial\Omega_n \right\} \quad (2.15)$$

admits solution. In the case where $\varphi_{\mathbf{P}}$ is a solution to (2.2), in Theorem 2.4 we obtain the identity result

$$\begin{aligned} \lim_n \min &\left\{ \frac{1}{|\Omega_n|} \mathcal{S}_n(\mathbf{P}) : \mathbf{P} \in (H^1(\Omega_n))^3 : \mathbf{P} \cdot \boldsymbol{\nu} = 0 \text{ on } \partial\Omega_n \right\} \\ &= \lim_n \min \left\{ \frac{1}{|\Omega_n|} \mathcal{E}_n(\mathbf{P}) : \mathbf{P} \in (H^1(\Omega_n))^3 : \mathbf{P} \cdot \boldsymbol{\nu} = 0 \text{ on } \partial\Omega_n \right\} \end{aligned} \quad (2.16)$$

where the limit it is given by (2.11). Moreover, (2.16) is true when $\varphi_{\mathbf{P}}$ is the solution to (2.3), too.

By considering this kind of results, we can explicitly note that the energetic curl term does not give any contribution to the limit problem and the constant β weighting this energetic term does not appear in the limit problem.

If in problems (2.5) and (2.15) the boundary condition $\mathbf{P} \cdot \boldsymbol{\nu} = 0$ is replaced by $\mathbf{P} \wedge \boldsymbol{\nu} = 0$ on $\partial\Omega_n$, it is easily seen that the limit of the energy is zero (for instance, compare [47]).

The chapter is organized in the following way. In Section 2.2, previous problems are rescaled on a fixed domain independent of n . Section 2.3 is devoted to introduce the constant η defined in (2.9) which appears in the limit of the nonlocal term. Section 2.4 is the heart of the paper. According to the several boundary conditions on the polarization, different limit behaviors of the polarization are expected, and consequently also different behaviors of the nonlocal term could be produced. Indeed,

in Proposition 2.4.2 we prove that if the potential generating the nonlocal term is solution to problem (2.2), then really the limit of the nonlocal term depends on boundary conditions on the polarization and we give a very general formula for the limit of the nonlocal term which covers all the possible cases coming from several boundary conditions on the polarization. If the potential generating the nonlocal term is the solution to problem (2.3), in Proposition 2.4.3 we prove that the limit of the nonlocal term is independent of the boundary conditions on the polarization and, precisely, it is always zero. Finally, using the main ideas of the Γ -convergence method introduced in [33] (see also [12], [17], and [32]), in Sections 2.5, 2.6, 2.7, and 2.8 we study the asymptotic behavior of problems (2.4), (2.5), (2.6), and (2.15), respectively, obtaining L^2 -strong convergences on the rescaled polarization p_n , on the rescaled potential φ_{p_n} , and on their rescaled gradients. In Section 2.9 we just sketch what happens when the potential generating the nonlocal term is the solution to problem (2.3).

Ferroelectric thin films and wires were studied in [46] and [47], respectively. The junction of ferroelectric thin films was examined in [16].

The 3D model of ferromagnetic microstructures is close to our model. For the limit behavior of ferromagnetic problems in thin structures involving wires we refer to [3], [4], [19], [20], [42], [43], [45], [50], [69], [70], and the references therein. For other optimal control problems on a network of half-lines sharing an endpoint, we refer to [2] and the references therein. For other recent problems in a thin T-like shaped structure, we refer to [15] and the references therein.

2.2 The rescaled problems

In the sequel, often we omit the symbol \cdot to denote the inner product in \mathbb{R}^3 .

As in [28], Problems (2.4), (2.5), (2.6), and (2.15) are reformulated on a fixed domain through the maps

$$\begin{cases} x = (x_1, x_2, x_3) \in \Omega^a =]-\frac{1}{2}, \frac{1}{2}[^2 \times]0, 1[\rightarrow (h_n x_1, h_n x_2, x_3) \in \text{Int}(\Omega_n^a), \\ x = (x_1, x_2, x_3) \in \Omega^b =]-\frac{1}{2}, \frac{1}{2}[^2 \times]-1, 0[\rightarrow (x_1, h_n x_2, h_n x_3) \in \Omega_n^b, \end{cases} \quad (2.17)$$

where $\text{Int}(\Omega_n^a)$ denotes the interior of Ω_n^a . Precisely, for every $n \in \mathbb{N}$ set

$$D_n^a : p^a \in \left(H^1(\Omega^a) \right)^k \rightarrow \left(\frac{1}{h_n} \frac{\partial p^a}{\partial x_1}, \frac{1}{h_n} \frac{\partial p^a}{\partial x_2}, \frac{\partial p^a}{\partial x_3} \right) \in \left(L^2(\Omega^a) \right)^{3k}, \quad k \in \{1, 3\},$$

$$D_n^b : p^b \in \left(H^1(\Omega^b) \right)^k \rightarrow \left(\frac{\partial p^b}{\partial x_1}, \frac{1}{h_n} \frac{\partial p^b}{\partial x_2}, \frac{1}{h_n} \frac{\partial p^b}{\partial x_3} \right) \in \left(L^2(\Omega^b) \right)^{3k}, \quad k \in \{1, 3\},$$

$$\text{div}_n^a : p^a = (p_1^a, p_2^a, p_3^a) \in \left(H^1(\Omega^a) \right)^3 \rightarrow \frac{1}{h_n} \frac{\partial p_1^a}{\partial x_1} + \frac{1}{h_n} \frac{\partial p_2^a}{\partial x_2} + \frac{\partial p_3^a}{\partial x_3} \in L^2(\Omega^a),$$

$$\text{div}_n^b : p^b = (p_1^b, p_2^b, p_3^b) \in \left(H^1(\Omega^b) \right)^3 \rightarrow \frac{\partial p_1^b}{\partial x_1} + \frac{1}{h_n} \frac{\partial p_2^b}{\partial x_2} + \frac{1}{h_n} \frac{\partial p_3^b}{\partial x_3} \in L^2(\Omega^b),$$

$$\text{rot}_n^a : p^a = (p_1^a, p_2^a, p_3^a) \in \left(H^1(\Omega^a) \right)^3 \rightarrow \left(\frac{1}{h_n} \frac{\partial p_3^a}{\partial x_2} - \frac{\partial p_2^a}{\partial x_3}, \frac{\partial p_1^a}{\partial x_3} - \frac{1}{h_n} \frac{\partial p_3^a}{\partial x_1}, \frac{1}{h_n} \frac{\partial p_2^a}{\partial x_1} - \frac{1}{h_n} \frac{\partial p_1^a}{\partial x_2} \right) \in \left(L^2(\Omega^a) \right)^3,$$

$$\text{rot}_n^b : p^b = (p_1^b, p_2^b, p_3^b) \in \left(H^1(\Omega^a) \right)^3 \rightarrow \left(\frac{1}{h_n} \frac{\partial p_3^b}{\partial x_2} - \frac{1}{h_n} \frac{\partial p_2^b}{\partial x_3}, \frac{1}{h_n} \frac{\partial p_1^b}{\partial x_3} - \frac{\partial p_3^b}{\partial x_1}, \frac{\partial p_2^b}{\partial x_1} - \frac{1}{h_n} \frac{\partial p_1^b}{\partial x_2} \right) \in \left(L^2(\Omega^b) \right)^3,$$

and

$$\begin{cases} f_n^a : x = (x_1, x_2, x_3) \in \Omega^a \rightarrow \mathbf{F}_n(h_n x_1, h_n x_2, x_3), \\ f_n^b : x = (x_1, x_2, x_3) \in \Omega^b \rightarrow \mathbf{F}_n(x_1, h_n x_2, h_n x_3), \end{cases} \quad (2.18)$$

and define the sets

$$P_n = \left\{ (p^a, p^b) \in \left(H^1(\Omega^a) \right)^3 \times \left(H^1(\Omega^b) \right)^3 : p^a(x_1, x_2, 0) = p^b(h_n x_1, x_2, 0) \text{ on } \left] -\frac{1}{2}, \frac{1}{2} \right[{}^2 \right\},$$

$$\tilde{P}_n = \left\{ (p^a, p^b) \in \left(H^1(\Omega^a) \right)^3 \times \left(H^1(\Omega^b) \right)^3 : p^a \cdot \nu^a = 0 \text{ on } \partial\Omega^a \setminus \left(\left] -\frac{1}{2}, \frac{1}{2} \right[{}^2 \times \{0\} \right), \right.$$

$$p^b \cdot \nu^b = 0 \text{ on } \partial\Omega^b \setminus \left(\left] -\frac{1}{2}, \frac{1}{2} \right[{}^2 \times \{0\} \right), p_3^b = 0 \text{ on } \left(\left] -\frac{1}{2}, \frac{1}{2} \right[\setminus \left] -\frac{h_n}{2}, \frac{h_n}{2} \right[\right) \times \left] -\frac{1}{2}, \frac{1}{2} \right[\times \{0\},$$

$$p^a(x_1, x_2, 0) = p^b(h_n x_1, x_2, 0) \text{ on } \left] -\frac{1}{2}, \frac{1}{2} \right[{}^2 \right\},$$

$$\begin{aligned}
P_n^* &= \left\{ (p^a, p^b) \in (H^1(\Omega^a))^3 \times (H^1(\Omega^b))^3 : p^a // e_3 \text{ on } \partial\Omega^a \setminus \left(]-\frac{1}{2}, \frac{1}{2}[^2 \times \{0\} \right), \right. \\
& p^b // e_3 \text{ on } \partial\Omega^b \setminus \left(]-\frac{1}{2}, \frac{1}{2}[^2 \times \{0\} \right), p_1^b = p_2^b = 0 \text{ on } \left(]-\frac{1}{2}, \frac{1}{2}[\setminus]-\frac{h_n}{2}, \frac{h_n}{2}[\right) \times]-\frac{1}{2}, \frac{1}{2}[\times \{0\}, \\
& p^a(x_1, x_2, 0) = p^b(h_n x_1, x_2, 0) \text{ on }]-\frac{1}{2}, \frac{1}{2}[^2 \left. \right\}, \\
U_n &= \left\{ (\phi^a, \phi^b) \in H^1(\Omega^a) \times H^1(\Omega^b) : \phi^a(x_1, x_2, 0) = \phi^b(h_n x_1, x_2, 0) \text{ on }]-\frac{1}{2}, \frac{1}{2}[^2 \right\}, \quad (2.19)
\end{aligned}$$

and

$$\begin{aligned}
U_n^0 &= \left\{ (\phi^a, \phi^b) \in H^1(\Omega^a) \times H^1(\Omega^b) : \phi^a = 0 \text{ on } \partial\Omega^a \setminus \left(]-\frac{1}{2}, \frac{1}{2}[^2 \times \{0\} \right), \right. \\
& \phi^b = 0 \text{ on } \partial\Omega^b \setminus \left(]-\frac{1}{2}, \frac{1}{2}[^2 \times \{0\} \right), \\
& \phi^b = 0 \text{ on } \left(]-\frac{1}{2}, \frac{1}{2}[\setminus]-\frac{h_n}{2}, \frac{h_n}{2}[\right) \times]-\frac{1}{2}, \frac{1}{2}[\times \{0\}, \\
& \left. \phi^a(x_1, x_2, 0) = \phi^b(h_n x_1, x_2, 0) \text{ on }]-\frac{1}{2}, \frac{1}{2}[^2 \right\}, \quad (2.20)
\end{aligned}$$

where ν^a and ν^b denote the unit outer normals on $\partial\Omega^a$ and $\partial\Omega^b$, respectively. Then \mathcal{E}_n and \mathcal{S}_n , defined in (2.1) and (2.14), respectively, are rescaled by

$$\begin{aligned}
E_n : (p^a, p^b) \in P_n &\rightarrow h_n^2 \int_{\Omega^a} \left(|D_n^a p^a|^2 + \alpha (|p^a|^2 - 1)^2 + |D_n^a \phi_{(p^a, p^b)}^a|^2 + f_n^a p^a \right) dx \\
&+ h_n^2 \int_{\Omega^b} \left(|D_n^b p^b|^2 + \alpha (|p^b|^2 - 1)^2 + |D_n^b \phi_{(p^a, p^b)}^b|^2 + f_n^b p^b \right) dx, \quad (2.21)
\end{aligned}$$

and

$$\begin{aligned}
S_n : (p^a, p^b) \in P_n &\rightarrow \\
&h_n^2 \int_{\Omega^a} \left(\beta |\text{rot}_n^a p^a|^2 + |\text{div}_n^a p^a|^2 + \alpha (|p^a|^2 - 1)^2 + |D_n^a \phi_{(p^a, p^b)}^a|^2 + f_n^a p^a \right) dx \\
&+ h_n^2 \int_{\Omega^b} \left(\beta |\text{rot}_n^b p^b|^2 + |\text{div}_n^b p^b|^2 + \alpha (|p^b|^2 - 1)^2 + |D_n^b \phi_{(p^a, p^b)}^b|^2 + f_n^b p^b \right) dx, \quad (2.22)
\end{aligned}$$

respectively, where $(\phi_{(p^a, p^b)}^a, \phi_{(p^a, p^b)}^b)$ is the unique solution to

$$\begin{cases} (\phi_{(p^a, p^b)}^a, \phi_{(p^a, p^b)}^b) \in \mathbf{U}_n, & \int_{\Omega^a} \phi_{(p^a, p^b)}^a dx = 0, \\ \int_{\Omega^a} (-D_n^a \phi_{(p^a, p^b)}^a + p^a) D_n^a \phi_{(p^a, p^b)}^a dx + \int_{\Omega^b} (-D_n^b \phi_{(p^a, p^b)}^b + p^b) D_n^b \phi_{(p^a, p^b)}^b dx = 0, \\ \forall (\phi^a, \phi^b) \in \mathbf{U}_n, \end{cases} \quad (2.23)$$

which rescales the weak formulation of (2.7), *i.e.*

$$\varphi_{\mathbf{P}} \in H^1(\Omega_n), \quad \int_{\Omega_n^a} \varphi_{\mathbf{P}} dx = 0, \quad \int_{\Omega_n} (-D \varphi_{\mathbf{P}} + \mathbf{P}) D \varphi dx = 0, \quad \forall \varphi \in H^1(\Omega_n). \quad (2.24)$$

The Lax-Milgram Theorem provides that (2.24) admits solutions and it is unique.

The main goal of this paper becomes to study the asymptotic behavior, as n diverges, of the following problems

$$\min \left\{ E_n((p^a, p^b)) : (p^a, p^b) \in \mathbf{P}_n \right\}, \quad (2.25)$$

$$\min \left\{ E_n((p^a, p^b)) : (p^a, p^b) \in \tilde{\mathbf{P}}_n \right\}, \quad (2.26)$$

$$\min \left\{ E_n((p^a, p^b)) : (p^a, p^b) \in \mathbf{P}_n^* \right\}, \quad (2.27)$$

and

$$\min \left\{ S_n((p^a, p^b)) : (p^a, p^b) \in \tilde{\mathbf{P}}_n \right\}. \quad (2.28)$$

Moreover, we also study the asymptotic behavior, as n diverges, of previous problems when in (2.21) and in (2.22) $(\phi_{(p^a, p^b)}^a, \phi_{(p^a, p^b)}^b)$ is the unique solution to

$$\begin{cases} (\phi_{(p^a, p^b)}^a, \phi_{(p^a, p^b)}^b) \in \mathbf{U}_n^0, \\ \int_{\Omega^a} (-D_n^a \phi_{(p^a, p^b)}^a + p^a) D_n^a \phi_{(p^a, p^b)}^a dx + \int_{\Omega^b} (-D_n^b \phi_{(p^a, p^b)}^b + p^b) D_n^b \phi_{(p^a, p^b)}^b dx = 0, \\ \forall (\phi^a, \phi^b) \in \mathbf{U}_n^0, \end{cases} \quad (2.29)$$

which rescales the weak formulation of (2.8), i.e.

$$\varphi_{\mathbf{P}} \in H_0^1(\Omega_n), \quad \int_{\Omega_n} (-D\varphi_{\mathbf{P}} + \mathbf{P}) D\varphi \, dx = 0, \quad \forall \varphi \in H_0^1(\Omega_n).$$

In the sequel, we assume

$$\begin{cases} f_n^a \rightharpoonup f^a & \text{weakly in } (L^2(\Omega^a))^3, \\ f_n^b \rightharpoonup f^b & \text{weakly in } (L^2(\Omega^b))^3. \end{cases} \quad (2.30)$$

2.3 Preliminaries

Let (y, z) denote the coordinates in \mathbb{R}^2 . Obviously, each one of the following problems

$$\begin{cases} r \in H^1 \left(\left] -\frac{1}{2}, \frac{1}{2} \right[\right]^2, \quad \int_{\left] -\frac{1}{2}, \frac{1}{2} \right[\right]^2} r \, dy \, dz = 0, \\ \int_{\left] -\frac{1}{2}, \frac{1}{2} \right[\right]^2} D_r D\phi \, dy \, dz = \int_{\left] -\frac{1}{2}, \frac{1}{2} \right[\right]^2} D_y \phi \, dy \, dz, \quad \forall \phi \in H^1 \left(\left] -\frac{1}{2}, \frac{1}{2} \right[\right]^2, \end{cases} \quad (2.31)$$

$$\begin{cases} s \in H^1 \left(\left] -\frac{1}{2}, \frac{1}{2} \right[\right]^2, \quad \int_{\left] -\frac{1}{2}, \frac{1}{2} \right[\right]^2} s \, dy \, dz = 0, \\ \int_{\left] -\frac{1}{2}, \frac{1}{2} \right[\right]^2} D_s D\phi \, dy \, dz = \int_{\left] -\frac{1}{2}, \frac{1}{2} \right[\right]^2} D_z \phi \, dy \, dz, \quad \forall \phi \in H^1 \left(\left] -\frac{1}{2}, \frac{1}{2} \right[\right]^2, \end{cases} \quad (2.32)$$

$$\begin{cases} t_c \in H^1 \left(\left] -\frac{1}{2}, \frac{1}{2} \right[\right]^2, \quad \int_{\left] -\frac{1}{2}, \frac{1}{2} \right[\right]^2} t_c \, dy \, dz = 0, \\ \int_{\left] -\frac{1}{2}, \frac{1}{2} \right[\right]^2} D t_c D\phi \, dy \, dz = \int_{\left] -\frac{1}{2}, \frac{1}{2} \right[\right]^2} c D\phi \, dy \, dz, \quad \forall \phi \in H^1 \left(\left] -\frac{1}{2}, \frac{1}{2} \right[\right]^2, \end{cases} \quad (2.33)$$

with $c = (c_1, c_2) \in \mathbb{R}^2$, admits a unique solution.

Note that (compare also [21])

$$s(y, z) = r(z, -y), \text{ a.e. in } \left] -\frac{1}{2}, \frac{1}{2} \right[{}^2,$$

consequently

$$Ds(y, z) = (-(D_z r)(z, -y), (D_y r)(z, -y)), \text{ a.e. in } \left] -\frac{1}{2}, \frac{1}{2} \right[{}^2,$$

from which one obtains

$$\int_{\left] -\frac{1}{2}, \frac{1}{2} \right[{}^2} |Ds|^2 dy dz = \int_{\left] -\frac{1}{2}, \frac{1}{2} \right[{}^2} |Dr|^2 dy dz \quad \text{and} \quad \int_{\left] -\frac{1}{2}, \frac{1}{2} \right[{}^2} Dr Ds dy dz = 0. \quad (2.34)$$

Then, we set

$$\eta = \int_{\left] -\frac{1}{2}, \frac{1}{2} \right[{}^2} |Ds|^2 dy dz = \int_{\left] -\frac{1}{2}, \frac{1}{2} \right[{}^2} |Dr|^2 dy dz. \quad (2.35)$$

In the sequel, we shall use the following result.

LEMMA 2.1. *Let r and s be the unique solutions to (2.31) and (2.32), respectively. Then, for every $c = (c_1, c_2)$ in \mathbb{R}^2 , the unique solution t_c to (2.33) is given by*

$$t_c = c_1 r + c_2 s.$$

We recall the Poincaré Lemma in an open bounded set (for instance, see [27], Th. 6.17-4)

LEMMA 2.2. *Let $\xi \in \left(L^2 \left(\left] -\frac{1}{2}, \frac{1}{2} \right[{}^2 \right) \right)^2$ such that $\text{rot } \xi = 0$. Then, there exists $w \in H^1 \left(\left] -\frac{1}{2}, \frac{1}{2} \right[{}^2 \right)$ such that $\xi = Dw$. Moreover, w is unique up to an additive constant.*

2.4 Two convergence results for the nonlocal term

This section is devoted to studying the asymptotic behavior of the nonlocal term generated by the potential solution to problem (2.23) or to problem (2.29).

Let

$$U = \left\{ (\psi^a, \psi^b) \in H^1([0, 1]) \times H^1\left(\left] -\frac{1}{2}, \frac{1}{2} \right[{}^2\right) : \psi^a(0) = \psi^b(0) \right\} \quad (2.36)$$

and

$$\mathbf{U}_{\text{reg}} = \left\{ (\psi^a, \psi^b) \in C^1([0, 1]) \times C\left(-\frac{1}{2}, \frac{1}{2}\right] : \psi^b|_{[-\frac{1}{2}, 0]} \in C^1\left(-\frac{1}{2}, 0\right], \quad \psi^b|_{[0, \frac{1}{2}]} \in C^1\left([0, \frac{1}{2}\right]), \right. \\ \left. \psi^a(0) = \psi^b(0) \right\}. \quad (2.37)$$

PROPOSITION 2.4.1. *Let \mathbf{U} and \mathbf{U}_{reg} be given by (2.36) and (2.37) respectively. Then \mathbf{U}_{reg} is dense in \mathbf{U} .*

Proof. Let $(\psi^a, \psi^b) \in \mathbf{U}$. The goal is to find a sequence $\{(\psi_n^a, \psi_n^b)\}_{n \in \mathbb{N}} \subset \mathbf{U}_{\text{reg}}$ such that

$$(\psi_n^a, \psi_n^b) \rightarrow (\psi^a, \psi^b) \quad \text{strongly in } H^1(]0, 1[) \times H^1\left(-\frac{1}{2}, \frac{1}{2}\right]. \quad (2.38)$$

To this end, split $\psi^b = \psi^e + \psi^o$ in the even part and in the odd part with respect to x_1 (compare [44] and [57]). Note that ψ^e and ψ^o belong to $H^1\left(-\frac{1}{2}, \frac{1}{2}\right]$, and

$$\psi^e(0) = \psi^b(0) = \psi^a(0), \quad \psi^o(0) = 0.$$

Consequently, a convolution argument allows us to build three sequences $\{\zeta_n^a\}_{n \in \mathbb{N}} \subset C^\infty(]0, 1[)$, $\{\zeta_n^e\}_{n \in \mathbb{N}} \subset C\left(-\frac{1}{2}, \frac{1}{2}\right]$ and $\{\zeta_n^o\}_{n \in \mathbb{N}} \subset C^\infty\left(-\frac{1}{2}, \frac{1}{2}\right]$ such that

$$\left\{ \begin{array}{l} \left\{ \zeta_n^e|_{[-\frac{1}{2}, 0]} \right\}_{n \in \mathbb{N}} \subset C^\infty\left(-\frac{1}{2}, 0\right], \quad \left\{ \zeta_n^e|_{[0, \frac{1}{2}]} \right\}_{n \in \mathbb{N}} \subset C^\infty\left([0, \frac{1}{2}\right]), \\ \zeta_n^a \rightarrow \psi^a \quad \text{strongly in } H^1(]0, 1[), \\ \zeta_n^e \rightarrow \psi^e \quad \text{strongly in } H^1\left(-\frac{1}{2}, \frac{1}{2}\right], \\ \zeta_n^o \rightarrow \zeta^o \quad \text{strongly in } H^1\left(-\frac{1}{2}, \frac{1}{2}\right], \\ \zeta_n^a(0) = \zeta_n^o(0), \quad \zeta_n^o(0) = 0, \quad \forall n \in \mathbb{N}. \end{array} \right. \quad (2.39)$$

This implies (2.38), setting $\psi_n^a = \zeta_n^a$ and $\psi_n^b = \zeta_n^e + \zeta_n^o$. □

PROPOSITION 2.4.2. *Let $\{(q_n^a, q_n^b)\}_{n \in \mathbb{N}} \subset (L^2(\Omega^a))^3 \times (L^2(\Omega^b))^3$, and let $(q^a, q^b) = ((q_1^a, q_2^a, q_3^a), (q_1^b, q_2^b, q_3^b)) \in (L^2(\Omega^a))^3 \times (L^2(\Omega^b))^3$ be such that q^a is independent of (x_1, x_2) , q^b is independent of (x_2, x_3) and*

$$(q_n^a, q_n^b) \rightarrow (q^a, q^b) \quad \text{strongly in } \left(L^2(\Omega^a)\right)^3 \times \left(L^2(\Omega^b)\right)^3. \quad (2.40)$$

Moreover, for $n \in \mathbb{N}$ let $(\phi_{(q_n^a, q_n^b)}^a, \phi_{(q_n^a, q_n^b)}^b)$ be the unique solution to

$$\begin{cases} (\phi_{(q_n^a, q_n^b)}^a, \phi_{(q_n^a, q_n^b)}^b) \in \mathcal{U}_n, & \int_{\Omega^a} \phi_{(q_n^a, q_n^b)}^a dx = 0, \\ \int_{\Omega^a} (-D_n^a \phi_{(q_n^a, q_n^b)}^a + q_n^a) D_n^a \phi^a dx + \int_{\Omega^b} (-D_n^b \phi_{(q_n^a, q_n^b)}^b + q_n^b) D_n^b \phi^b dx = 0 \quad \forall (\phi^a, \phi^b) \in \mathcal{U}_n, \end{cases} \quad (2.41)$$

where \mathcal{U}_n is defined in (2.19). Then,

$$\begin{cases} \phi_{(q_n^a, q_n^b)}^a \rightarrow \int_0^{x_3} q_3^a(t) dt - \int_0^1 \left(\int_0^{x_3} q_3^a(t) dt \right) dx_3 & \text{strongly in } (H^1(\Omega^a)), \\ \phi_{(q_n^a, q_n^b)}^b \rightarrow \int_{-\frac{1}{2}}^{x_1} q_1^b(t) dt - \int_0^1 \left(\int_0^{x_3} q_3^a(t) dt \right) dx_3 - \int_{-\frac{1}{2}}^0 q_1^b(t) dt & \text{strongly in } (H^1(\Omega^b)), \\ \left(\frac{1}{h_n} \frac{\partial \phi_{(q_n^a, q_n^b)}^a}{\partial x_1}, \frac{1}{h_n} \frac{\partial \phi_{(q_n^a, q_n^b)}^a}{\partial x_2} \right) \rightarrow q_1^a D r + q_2^a D s & \text{strongly in } (L^2(\Omega^a))^2, \\ \left(\frac{1}{h_n} \frac{\partial \phi_{(q_n^a, q_n^b)}^b}{\partial x_2}, \frac{1}{h_n} \frac{\partial \phi_{(q_n^a, q_n^b)}^b}{\partial x_3} \right) \rightarrow q_2^b D \bar{r} + q_3^b D \bar{s} & \text{strongly in } (L^2(\Omega^b))^2, \end{cases} \quad (2.42)$$

and

$$\begin{aligned} \lim_n \left(\int_{\Omega^a} |D_n^a \phi_{(q_n^a, q_n^b)}^a|^2 dx + \int_{\Omega^b} |D_n^b \phi_{(q_n^a, q_n^b)}^b|^2 dx \right) &= \eta \int_0^1 (|q_1^a|^2 + |q_2^a|^2) dx_3 + \int_0^1 |q_3^a|^2 dx_3 \\ &+ \int_{-\frac{1}{2}}^{\frac{1}{2}} |q_1^b|^2 dx_1 + \eta \int_{-\frac{1}{2}}^{\frac{1}{2}} (|q_2^b|^2 + |q_3^b|^2) dx_1. \end{aligned} \quad (2.43)$$

where r and s are the unique solutions to (2.31) and (2.32), respectively, \bar{r} and \bar{s} are defined by

$$\bar{r} = r \left(x_2, x_3 + \frac{1}{2} \right), \quad \bar{s} = s \left(x_2, x_3 + \frac{1}{2} \right), \quad \text{a.e. in } \left] -\frac{1}{2}, \frac{1}{2} \right[\times]0, 1[,$$

and η is defined in (2.35).

Proof. In this proof, C denotes any positive constant independent of $n \in \mathbb{N}$.

Choosing $(\phi^a, \phi^b) = (\phi_{(q_n^a, q_n^b)}^a, \phi_{(q_n^a, q_n^b)}^b)$ as test function in (2.41), applying Young inequality, and using (2.40) give

$$\|D_n^a \phi_{(q_n^a, q_n^b)}^a\|_{(L^2(\Omega^a))^3} \leq C, \quad \|D_n^b \phi_{(q_n^a, q_n^b)}^b\|_{(L^2(\Omega^b))^3} \leq C, \quad \forall n \in \mathbb{N}. \quad (2.44)$$

The first estimate in (2.44) implies

$$\|\Phi_{(q_n^a, q_n^b)}^a\|_{H^1(\Omega^a)} \leq C, \quad \forall n \in \mathbb{N}, \quad (2.45)$$

since $\int_{\Omega^a} \Phi_{(q_n^a, q_n^b)}^a dx = 0$ and the Poincaré-Wirtinger inequality holds.

The next step is devoted to proving

$$\|\Phi_{(q_n^a, q_n^b)}^b\|_{H^1(\Omega^b)} \leq C, \quad \forall n \in \mathbb{N}. \quad (2.46)$$

The junction condition in (2.19) gives

$$\begin{aligned} \int_{]-\frac{h_n}{2}, \frac{h_n}{2}[\times]-\frac{1}{2}, \frac{1}{2}[} \left| \Phi_{(q_n^a, q_n^b)}^b(x_1, x_2, 0) \right|^2 dx_1 dx_2 &= h_n \int_{]-\frac{1}{2}, \frac{1}{2}[} \left| \Phi_{(q_n^a, q_n^b)}^b(h_n x_1, x_2, 0) \right|^2 dx_1 dx_2 \\ &= h_n \int_{]-\frac{1}{2}, \frac{1}{2}[} \left| \Phi_{(q_n^a, q_n^b)}^a(x_1, x_2, 0) \right|^2 dx_1 dx_2, \quad \forall n \in \mathbb{N}. \end{aligned} \quad (2.47)$$

Then, (2.47), (2.45) and the trace theorem provide

$$\|\Phi_{(q_n^a, q_n^b)}^b\|_{L^2(]-\frac{h_n}{2}, \frac{h_n}{2}[\times]-\frac{1}{2}, \frac{1}{2}[\times \{0\})} \leq \sqrt{h_n} C, \quad \forall n \in \mathbb{N},$$

which implies

$$\|\Phi_{(q_n^a, q_n^b)}^b\|_{H^1(]-\frac{h_n}{2}, \frac{h_n}{2}[\times]-\frac{1}{2}, \frac{1}{2}[\times]-1, 0[)} \leq C, \quad \forall n \in \mathbb{N}, \quad (2.48)$$

by virtue of the second estimates in (2.44). Consequently, by virtue of trace theorem,

$$\|\Phi_{(q_n^a, q_n^b)}^b\|_{L^2(\{0\} \times]-\frac{1}{2}, \frac{1}{2}[\times]-1, 0[)} \leq C, \quad \forall n \in \mathbb{N},$$

which combined again with the second estimates in (2.44) proves (2.46). Estimates (2.44), (2.45), and (2.46) ensure the existence of a subsequence of \mathbb{N} , still denoted by $\{n\}$ and (in possible dependence on the subsequence) $(\tau^a, \tau^b) \in \mathcal{U}$ defined in (2.36), $(\xi^a, \zeta^a) \in (L^2(\Omega^a))^2$ and $(\xi^b, \zeta^b) \in (L^2(\Omega^b))^2$ such that

$$\left(\Phi_{(q_n^a, q_n^b)}^a, \Phi_{(q_n^a, q_n^b)}^b \right) \rightharpoonup (\tau^a, \tau^b) \text{ weakly in } H^1(\Omega^a) \times H^1(\Omega^b), \quad (2.49)$$

$$\left(\frac{1}{h_n} \frac{\partial \Phi_{(q_n^a, q_n^b)}^a}{\partial x_1}, \frac{1}{h_n} \frac{\partial \Phi_{(q_n^a, q_n^b)}^a}{\partial x_2} \right) \rightharpoonup (\xi^a, \zeta^a) \text{ weakly in } \left(L^2(\Omega^a) \right)^2, \quad (2.50)$$

$$\left(\frac{1}{h_n} \frac{\partial \phi_{(q_n^a, q_n^b)}^b}{\partial x_2}, \frac{1}{h_n} \frac{\partial \phi_{(q_n^a, q_n^b)}^b}{\partial x_3} \right) \rightharpoonup (\xi^b, \zeta^b) \text{ weakly in } \left(L^2(\Omega^b) \right)^2, \quad (2.51)$$

and

$$\int_0^1 \tau^a dx_3 = 0. \quad (2.52)$$

Note that the junction condition $\tau^a(0) = \tau^b(0)$ can be obtained arguing as in [42], while (2.52) follows from $\int_{\Omega^a} \phi_{(q_n^a, q_n^b)}^a dx = 0$.

The next step is devoted to identify (τ^a, τ^b) . To this end, for every couple $(\psi^a, \psi^b) \in \mathcal{U}_{\text{reg}}$ where \mathcal{U}_{reg} is defined in (2.37), consider a sequence $\{\mu_n\}_{n \in \mathbb{N}} \subset H^1(\Omega^a)$ (depending on (ψ^a, ψ^b)) such that

$$\left\{ \begin{array}{l} (\mu_n, \psi^b) \in \mathcal{U}_n, \quad \forall n \in \mathbb{N}, \\ \mu_n \rightarrow \psi^a \text{ strongly in } L^2(\Omega^a), \\ \left(\frac{1}{h_n} \frac{\partial \mu_n}{\partial x_1}, \frac{1}{h_n} \frac{\partial \mu_n}{\partial x_2}, \frac{\partial \mu_n}{\partial x_3} \right) \rightarrow \left(0, 0, \frac{d\psi^a}{dx_3} \right) \text{ strongly in } \left(L^2(\Omega^a) \right)^3. \end{array} \right. \quad (2.53)$$

For instance, setting

$$\mu_n(x) = \begin{cases} \psi^a(x_3) & \text{if } x = (x_1, x_2, x_3) \in]-\frac{1}{2}, \frac{1}{2}[^2 \times]h_n, 1[, \\ \psi^a(h_n) \frac{x_3}{h_n} + \psi^b(h_n x_1) \frac{h_n - x_3}{h_n} & \text{if } x = (x_1, x_2, x_3) \in]-\frac{1}{2}, \frac{1}{2}[^2 \times [0, h_n], \end{cases} \quad (2.54)$$

the first two properties in (2.53) can be immediately verified by the properties of \mathcal{U}_{reg} , while the last ones follows from

$$\begin{aligned} \int_{]-\frac{1}{2}, \frac{1}{2}[^2 \times]0, h_n[} \left| \frac{1}{h_n} \frac{\partial \mu_n}{\partial x_1} \right|^2 dx &= \int_{]-\frac{1}{2}, \frac{1}{2}[^2 \times]0, h_n[} \left| \frac{d\psi^b}{dx_1}(h_n x_1) \left(1 - \frac{x_3}{h_n} \right) \right|^2 dx \\ &= \int_{]-\frac{1}{2}, \frac{1}{2}[^2} \left| \frac{d\psi^b}{dx_1}(h_n x_1) \right|^2 dx_1 dx_2 \int_0^{h_n} \left(1 - \frac{x_3}{h_n} \right)^2 dx_3 \leq \|\psi^b\|_{W^{1,\infty}([-\frac{1}{2}, \frac{1}{2}])}^2 h_n, \quad \forall n \in \mathbb{N}, \\ \int_{]-\frac{1}{2}, \frac{1}{2}[^2 \times]0, h_n[} \left| \frac{1}{h_n} \frac{\partial \mu_n}{\partial x_2} \right|^2 dx &= 0, \quad \forall n \in \mathbb{N}, \end{aligned}$$

$$\begin{aligned}
& \int_{]-\frac{1}{2}, \frac{1}{2}[^2 \times]0, h_n[} \left| \frac{\partial \mu_n}{\partial x_3} \mu_n \right|^2 dx = \int_{]-\frac{1}{2}, \frac{1}{2}[^2 \times]0, h_n[} \left| \psi^a(h_n) \frac{1}{h_n} - \psi^b(h_n x_1) \frac{1}{h_n} \right|^2 dx \\
& = \int_{-\frac{1}{2}}^{\frac{1}{2}} \frac{1}{h_n} \left| \psi^a(h_n) - \psi^b(h_n x_1) \right|^2 dx_1 = \int_{-\frac{1}{2}}^{\frac{1}{2}} \frac{1}{h_n} \left| \psi^a(h_n) - \psi^a(0) + \psi^b(0) - \psi^b(h_n x_1) \right|^2 dx_1 \\
& \leq 2 \left(\|\psi^a\|_{W^{1,\infty}(]0,1])}^2 + \|\psi^b\|_{W^{1,\infty}(]-\frac{1}{2}, \frac{1}{2}[)}^2 \right) h_n, \quad \forall n \in \mathbb{N},
\end{aligned}$$

where again the properties of \mathcal{U}_{reg} played a crucial role.

Now, fixing $(\psi^a, \psi^b) \in \mathcal{U}_{\text{reg}}$, choosing (μ_n, ψ^b) as test function in (2.41) with μ_n satisfying (2.53), passing to the limit as n diverges, and using (2.40), (2.49)-(2.51), one obtains

$$\int_0^1 \left(-\frac{d\tau^a}{dx_3} + q_3^a \right) \frac{d\psi^a}{dx_3} dx_3 + \int_{-\frac{1}{2}}^{\frac{1}{2}} \left(-\frac{d\tau^b}{dx_1} + q_1^b \right) \frac{d\psi^b}{dx_1} dx_1 = 0. \quad (2.55)$$

By virtue of Proposition 2.4.1, equation (2.55) holds true also with any test function in \mathcal{U} . The uniqueness of the solution of this problem is ensured by (2.52) and the junction condition $\tau^a(0) = \tau^b(0)$. Consequently, (τ^a, τ^b) is given by

$$\begin{cases} \tau^a = \int_0^{x_3} q_3^a(t) dt - \int_0^1 \left(\int_0^{x_3} q_3^a(t) dt \right) dx_3, \\ \tau^b = \int_{-\frac{1}{2}}^{x_1} q_1^b(t) dt - \int_0^1 \left(\int_0^{x_3} q_3^a(t) dt \right) dx_3 - \int_{-\frac{1}{2}}^0 q_1^b(t) dt, \end{cases}$$

which combined with (2.49) proves that

$$\begin{cases} \Phi_{(q_n^a, q_n^b)}^a \rightharpoonup \int_0^{x_3} q_3^a(t) dt - \int_0^1 \left(\int_0^{x_3} q_3^a(t) dt \right) dx_3 & \text{weakly in } (H^1(\Omega^a)), \\ \Phi_{(q_n^a, q_n^b)}^b \rightharpoonup \int_{-\frac{1}{2}}^{x_1} q_1^b(t) dt - \int_0^1 \left(\int_0^{x_3} q_3^a(t) dt \right) dx_3 - \int_{-\frac{1}{2}}^0 q_1^b(t) dt & \text{weakly in } (H^1(\Omega^b)). \end{cases} \quad (2.56)$$

Let us identify (ξ^a, ζ^a) . To this aim, starting from the following evident relation

$$\frac{\partial}{\partial x_2} \left(\frac{1}{h_n} \frac{\partial \Phi_{(q_n^a, q_n^b)}^a}{\partial x_1} \right) = \frac{\partial}{\partial x_1} \left(\frac{1}{h_n} \frac{\partial \Phi_{(q_n^a, q_n^b)}^a}{\partial x_2} \right) \text{ in } \mathcal{D}'(\Omega^a), \quad \forall n \in \mathbb{N},$$

and using (2.50), one obtains that

$$\int_{\Omega^a} \xi^a \frac{\partial \varphi}{\partial x_2} dx = \int_{\Omega_a} \zeta^a \frac{\partial \varphi}{\partial x_1} dx, \quad \forall \varphi \in C_0^\infty(\Omega^a). \quad (2.57)$$

By taking $\varphi(x) = \phi(x_1, x_2)\chi(x_3)$ with $\phi \in C_0^\infty\left(]-\frac{1}{2}, \frac{1}{2}[^2\right)$ and $\chi \in C_0^\infty(]0, 1[)$ and recalling that $C_0^\infty\left(]-\frac{1}{2}, \frac{1}{2}[^2\right)$ is separable, it follows from (2.57) that

$$\left\{ \begin{array}{l} \text{for } x_3 \text{ a.e. in }]0, 1[\\ \int_{]-\frac{1}{2}, \frac{1}{2}[^2} \xi^a(x_1, x_2, x_3) \frac{\partial \phi}{\partial x_2}(x_1, x_2) dx_1 dx_2 = \int_{(]-\frac{1}{2}, \frac{1}{2}[)^2} \zeta^a(x_1, x_2, x_3) \frac{\partial \phi}{\partial x_1}(x_1, x_2) dx_1 dx_2, \\ \forall \phi \in C_0^\infty\left(]-\frac{1}{2}, \frac{1}{2}[^2\right). \end{array} \right.$$

Consequently, by virtue of the Poincaré Lemma recalled in Lemma 2.2, it results that

$$\left\{ \begin{array}{l} \text{for } x_3 \text{ a.e. in }]0, 1[, \quad \exists! w^a(\cdot, \cdot, x_3) \in H^1\left(]-\frac{1}{2}, \frac{1}{2}[^2\right) : \\ \int_{]-\frac{1}{2}, \frac{1}{2}[^2} w^a(x_1, x_2, x_3) dx_1 dx_2 = 0, \\ \xi^a(\cdot, \cdot, x_3) = \frac{\partial w^a(\cdot, \cdot, x_3)}{\partial x_1}, \quad \zeta^a(\cdot, \cdot, x_3) = \frac{\partial w^a(\cdot, \cdot, x_3)}{\partial x_2}, \quad \text{a.e. in }]-\frac{1}{2}, \frac{1}{2}[^2. \end{array} \right. \quad (2.58)$$

Passing to the limit in (2.41) with $(\phi^a, \phi^b) = (h_n \varphi \chi, 0)$ where $\varphi \in H^1\left(]-\frac{1}{2}, \frac{1}{2}[^2\right)$ and $\chi \in C_0^\infty(]0, 1[)$, and using (2.40), (2.56) and (2.50) give

$$\int_0^1 \left(\int_{]-\frac{1}{2}, \frac{1}{2}[^2} (\xi^a, \zeta^a) \left(\frac{\partial \varphi}{\partial x_1}, \frac{\partial \varphi}{\partial x_2} \right) dx_1 dx_2 \right) \chi dx_3 = \int_0^1 \left((q_1^a, q_2^a) \int_{]-\frac{1}{2}, \frac{1}{2}[^2} \left(\frac{\partial \varphi}{\partial x_1}, \frac{\partial \varphi}{\partial x_2} \right) dx_1 dx_2 \right) \chi dx_3, \\ \forall \varphi \in H^1\left(]-\frac{1}{2}, \frac{1}{2}[^2\right), \quad \forall \chi \in C_0^\infty(]0, 1[). \quad (2.59)$$

Consequently, since $H^1\left(]-\frac{1}{2}, \frac{1}{2}[^2\right)$ is separable, one obtains that

$$\left\{ \begin{array}{l} \text{for } x_3 \text{ a.e. in }]0, 1[, \\ \int_{]-\frac{1}{2}, \frac{1}{2}[^2} (\xi^\alpha(x_1, x_2, x_3), \zeta^\alpha(x_1, x_2, x_3)) \left(\frac{\partial \varphi}{\partial x_1}, \frac{\partial \varphi}{\partial x_2} \right) dx_1 dx_2 = (q_1^\alpha(x_3), q_2^\alpha(x_3)) \int_{]-\frac{1}{2}, \frac{1}{2}[^2} \left(\frac{\partial \varphi}{\partial x_1}, \frac{\partial \varphi}{\partial x_2} \right) dx_1 dx_2, \\ \forall \varphi \in H^1\left(]-\frac{1}{2}, \frac{1}{2}[^2\right), \end{array} \right. \quad (2.60)$$

from which, by virtue of (2.58), it follows that for x_3 a.e. in $]0, 1[$, $w^\alpha(\cdot, \cdot, x_3)$ solves the following problem

$$\left\{ \begin{array}{l} w^\alpha(\cdot, \cdot, x_3) \in H^1\left(]-\frac{1}{2}, \frac{1}{2}[^2\right), \quad \int_{]-\frac{1}{2}, \frac{1}{2}[^2} w^\alpha(x_1, x_2, x_3) dx_1 dx_2 = 0, \\ \int_{]-\frac{1}{2}, \frac{1}{2}[^2} \left(\frac{\partial w^\alpha}{\partial x_1}, \frac{\partial w^\alpha}{\partial x_2} \right) \left(\frac{\partial \varphi}{\partial x_1}, \frac{\partial \varphi}{\partial x_2} \right) dx_1 dx_2 = (q_1^\alpha(x_3), q_2^\alpha(x_3)) \int_{]-\frac{1}{2}, \frac{1}{2}[^2} \left(\frac{\partial \varphi}{\partial x_1}, \frac{\partial \varphi}{\partial x_2} \right) dx_1 dx_2 \\ \forall \varphi \in H^1\left(]-\frac{1}{2}, \frac{1}{2}[^2\right). \end{array} \right. \quad (2.61)$$

Then, by virtue of Lemma 2.1, it results that, for x_3 a.e. in $]0, 1[$,

$$w^\alpha(\cdot, \cdot, x_3) = q_1^\alpha(x_3)r(\cdot, \cdot) + q_2^\alpha(x_3)s(\cdot, \cdot), \text{ a.e. in }]-\frac{1}{2}, \frac{1}{2}[^2, \quad (2.62)$$

with r (resp. s) the unique solution to (2.31) (resp. (2.32)).

Finally, since Tonelli theorem assures that $q_1^\alpha D r_1 + q_2^\alpha D s_2$ belong to $(L^2(\Omega^\alpha))^2$, using Fubini theorem with (2.58) and (2.62) one entails that

$$\begin{aligned} \int_{\Omega^\alpha} (\xi^\alpha, \zeta^\alpha) \varphi dx &= \int_0^1 \left(\int_{]-\frac{1}{2}, \frac{1}{2}[^2} (\xi^\alpha, \zeta^\alpha) \varphi dx_1 dx_2 \right) dx_3 \\ &= \int_0^1 \left(\int_{]-\frac{1}{2}, \frac{1}{2}[^2} (q_1^\alpha D r + q_2^\alpha D s) \varphi dx_1 dx_2 \right) dx_3 \\ &= \int_{\Omega^\alpha} (q_1^\alpha D r + q_2^\alpha D s) \varphi dx, \quad \forall \varphi \in C_0^\infty(\Omega^\alpha), \end{aligned}$$

that is

$$(\xi^\alpha, \zeta^\alpha) = q_1^\alpha(x_3) D r(x_1, x_2) + q_2^\alpha(x_3) D s(x_1, x_2), \text{ a.e. in } \Omega^\alpha. \quad (2.63)$$

Then, combining (2.50) with (2.63) provides

$$\left(\frac{1}{h_n} \frac{\partial \phi_{(q_n^a, q_n^b)}^a}{\partial x_1}, \frac{1}{h_n} \frac{\partial \phi_{(q_n^a, q_n^b)}^a}{\partial x_2} \right) \rightharpoonup q_1^a D r + q_2^a D s \text{ weakly in } \left(L^2(\Omega^a) \right)^2. \quad (2.64)$$

Now, limits (2.40), (2.56), (2.64) imply

$$\lim_n \int_{\Omega^a} D_n^a \phi_{(q_n^a, q_n^b)}^a q_n^a dx = \int_{\Omega^a} (q_1^a D r + q_2^a D s)(q_1^a, q_2^a) dx + \int_0^1 |q_3^a|^2 dx_3. \quad (2.65)$$

On the other side, using equation (2.61) with test function $q_1^a(x_3)r(\cdot, \cdot) + q_2^a(x_3)s(\cdot, \cdot)$, for x_3 a.e. in $]0, 1[$, and taking into account (2.62), (2.34), and (2.35) give

$$\int_{\Omega^a} (q_1^a D r + q_2^a D s)(q_1^a, q_2^a) dx = \int_{\Omega^a} |q_1^a D r + q_2^a D s|^2 dx = \eta \int_0^1 (|q_1^a|^2 + |q_2^a|^2) dx_3 \quad (2.66)$$

Then, combining (2.65) and (2.66) provides

$$\lim_n \int_{\Omega^a} D_n^a \phi_{(q_n^a, q_n^b)}^a q_n^a dx = \eta \int_0^1 (|q_1^a|^2 + |q_2^a|^2) dx_3 + \int_0^1 |q_3^a|^2 dx_3 \quad (2.67)$$

Similarly, to identify (ξ^b, ζ^b) one has

$$\left\{ \begin{array}{l} \text{for } x_1 \text{ a.e. in }]-\frac{1}{2}, \frac{1}{2}[, \quad \exists! w^b(x_1, \cdot) \in H^1 \left(]-\frac{1}{2}, \frac{1}{2}[\times]-1, 0[\right) : \\ \int_{]-\frac{1}{2}, \frac{1}{2}[\times]-1, 0[} w^b(x_1, x_2, x_3) dx_2 dx_3 = 0, \\ \xi^b(x_1, \cdot, \cdot) = \frac{\partial w^b(x_1, \cdot, \cdot)}{\partial x_2}, \quad \zeta^b(x_1, \cdot, \cdot) = \frac{\partial w^b(x_1, \cdot, \cdot)}{\partial x_3}, \text{ a.e. in }]-\frac{1}{2}, \frac{1}{2}[\times]-1, 0[. \end{array} \right. \quad (2.68)$$

Passing to the limit in (2.41) with $(\phi^a, \phi^b) = (0, h_n \varphi \chi)$ where $\varphi \in H^1 \left(]-\frac{1}{2}, \frac{1}{2}[\times]-1, 0[\right)$ and $\chi \in C_0^\infty \left(]-\frac{1}{2}, 0[\cup]0, \frac{1}{2}[\right)$ (note that $(0, h_n \varphi \chi) \in \mathcal{U}_n$ for n large enough), and using (2.40), (2.56) and

(2.51) give

$$\begin{aligned} & \int_{-\frac{1}{2}}^{\frac{1}{2}} \left(\int_{]-\frac{1}{2}, \frac{1}{2}[\times]-1, 0[} (\xi^b, \zeta^b) \left(\frac{\partial \varphi}{\partial x_2}, \frac{\partial \varphi}{\partial x_3} \right) dx_2 dx_3 \right) \chi dx_1 \\ &= \int_{-\frac{1}{2}}^{\frac{1}{2}} \left((q_2^b, q_3^b) \int_{]-\frac{1}{2}, \frac{1}{2}[\times]-1, 0[} \left(\frac{\partial \varphi}{\partial x_2}, \frac{\partial \varphi}{\partial x_3} \right) dx_2 dx_3 \right) \chi dx_1, \end{aligned} \quad (2.69)$$

$$\forall \varphi \in H^1 \left(]-\frac{1}{2}, \frac{1}{2}[\times]-1, 0[\right), \quad \forall \chi \in C_0^\infty \left(]-\frac{1}{2}, 0[\cup]0, \frac{1}{2}[\right).$$

Consequently, since $H^1 \left(]-\frac{1}{2}, \frac{1}{2}[\times]-1, 0[\right)$ is separable, one obtains that

$$\left\{ \begin{array}{l} \text{for } x_1 \text{ a.e. in }]-\frac{1}{2}, \frac{1}{2}[, \\ \int_{]-\frac{1}{2}, \frac{1}{2}[\times]-1, 0[} (\xi^b, \zeta^b) \left(\frac{\partial \varphi}{\partial x_2}, \frac{\partial \varphi}{\partial x_3} \right) dx_2 dx_3 = (q_2^b(x_1), q_3^b(x_1)) \int_{]-\frac{1}{2}, \frac{1}{2}[\times]-1, 0[} \left(\frac{\partial \varphi}{\partial x_2}, \frac{\partial \varphi}{\partial x_3} \right) dx_2 dx_3, \\ \forall \varphi \in H^1 \left(]-\frac{1}{2}, \frac{1}{2}[\times]-1, 0[\right), \end{array} \right. \quad (2.70)$$

from which, by virtue of (2.68), it follows that for x_1 a.e. in $]-\frac{1}{2}, \frac{1}{2}[$, $w^b(x_1, \cdot, \cdot)$ solves the following problem

$$\left\{ \begin{array}{l} w^b(x_1, \cdot, \cdot) \in H^1 \left(]-\frac{1}{2}, \frac{1}{2}[\times]-1, 0[\right), \\ \int_{]-\frac{1}{2}, \frac{1}{2}[\times]-1, 0[} w^b(x_1, x_2, x_3) dx_2 dx_3 = 0, \\ \int_{]-\frac{1}{2}, \frac{1}{2}[\times]-1, 0[} \left(\frac{\partial w^b}{\partial x_2}, \frac{\partial w^b}{\partial x_3} \right) \left(\frac{\partial \varphi}{\partial x_2}, \frac{\partial \varphi}{\partial x_3} \right) dx_2 dx_3 = (q_2^b(x_1), q_3^b(x_1)) \int_{]-\frac{1}{2}, \frac{1}{2}[\times]-1, 0[} \left(\frac{\partial \varphi}{\partial x_2}, \frac{\partial \varphi}{\partial x_3} \right) dx_2 dx_3, \\ \forall \varphi \in H^1 \left(]-\frac{1}{2}, \frac{1}{2}[\times]-1, 0[\right), \end{array} \right.$$

Then, by virtue of Lemma 2.1, it results that, for x_1 a.e. in $]-\frac{1}{2}, \frac{1}{2}[$,

$$w^b(x_1, \cdot, \cdot) = q_1^a(x_1) \bar{r}(\cdot, \cdot) + q_2^a(x_1) \bar{s}(\cdot, \cdot), \quad \text{a.e. in } \left] -\frac{1}{2}, \frac{1}{2}[\times]-1, 0[\right),$$

where $\bar{r} = r(x_2, x_3 + \frac{1}{2})$, $\bar{s} = s(x_2, x_3 + \frac{1}{2})$.

Then, arguing as above, one obtains

$$\left(\frac{1}{h_n} \frac{\partial \phi_{(q_n^a, q_n^b)}^b}{\partial x_2}, \frac{1}{h_n} \frac{\partial \phi_{(q_n^a, q_n^b)}^b}{\partial x_3} \right) \rightharpoonup q_2^b D \bar{r} + q_3^b D \bar{s} \text{ weakly in } \left(L^2(\Omega^b) \right)^2 \quad (2.71)$$

and

$$\begin{aligned} \lim_n \int_{\Omega^b} D_n^b \phi_{(q_n^a, q_n^b)}^a q_n^b dx &= \int_{-\frac{1}{2}}^{\frac{1}{2}} |q_1^b|^2 dx_1 + \int_{\Omega^b} |q_2^b D\bar{r} + q_3^b D\bar{s}|^2 dx \\ &= \int_{-\frac{1}{2}}^{\frac{1}{2}} |q_1^b|^2 dx_1 + \eta \int_{-\frac{1}{2}}^{\frac{1}{2}} \left(|q_2^b|^2 + |q_3^b|^2 \right) dx_1. \end{aligned} \quad (2.72)$$

Passing to the limit in (2.41) with $(\phi^a, \phi^b) = (\phi_{(q_n^a, q_n^b)}^a, \phi_{(q_n^a, q_n^b)}^b)$ and using (2.67) and (2.72) one obtains the convergence of the energies

$$\begin{aligned} &\lim_n \left(\int_{\Omega^a} |D_n^a \phi_{(q_n^a, q_n^b)}^a|^2 dx + \int_{\Omega^b} |D_n^b \phi_{(q_n^a, q_n^b)}^b|^2 dx \right) \\ &= \lim_n \left(\int_{\Omega^a} D_n^a \phi_{(q_n^a, q_n^b)}^a q_n^a dx + \int_{\Omega^a} D_n^b \phi_{(q_n^a, q_n^b)}^b q_n^b dx \right) \\ &= \int_{\Omega^a} |q_1^a D\bar{r} + q_2^a D\bar{s}|^2 dx + \int_0^1 |q_3^a|^2 dx_3 + \int_{-\frac{1}{2}}^{\frac{1}{2}} |q_1^b|^2 dx_1 + \int_{\Omega^b} |q_2^b D\bar{r} + q_3^b D\bar{s}|^2 dx \\ &= \eta \int_0^1 (|q_1^a|^2 + |q_2^a|^2) dx_3 + \int_0^1 |q_3^a|^2 dx_3 + \int_{-\frac{1}{2}}^{\frac{1}{2}} |q_1^b|^2 dx_1 + \eta \int_{-\frac{1}{2}}^{\frac{1}{2}} \left(|q_2^b|^2 + |q_3^b|^2 \right) dx_1. \end{aligned} \quad (2.73)$$

Finally, (2.42) and (2.43) follow from (2.56), (2.64), (2.71), and (2.73). \square

PROPOSITION 2.4.3. *Let $\{(q_n^a, q_n^b)\}_{n \in \mathbb{N}} \subset (L^2(\Omega^a))^3 \times (L^2(\Omega^b))^3$, and let $(q^a, q^b) = ((q_1^a, q_2^a, q_3^a), (q_1^b, q_2^b, q_3^b)) \in (L^2(\Omega^a))^3 \times (L^2(\Omega^b))^3$ be such that q^a is independent of (x_1, x_2) , q^b is independent of (x_2, x_3) and*

$$(q_n^a, q_n^b) \rightarrow (q^a, q^b) \text{ strongly in } (L^2(\Omega^a))^3 \times (L^2(\Omega^b))^3. \quad (2.74)$$

Moreover, for $n \in \mathbb{N}$ let $(\phi_{(q_n^a, q_n^b)}^a, \phi_{(q_n^a, q_n^b)}^b)$ be the unique solution to

$$\begin{cases} (\phi_{(q_n^a, q_n^b)}^a, \phi_{(q_n^a, q_n^b)}^b) \in U_n^0, \\ \int_{\Omega^a} \left(-D_n^a \phi_{(q_n^a, q_n^b)}^a + q_n^a \right) D_n^a \phi^a dx + \int_{\Omega^b} \left(-D_n^b \phi_{(q_n^a, q_n^b)}^b + q_n^b \right) D_n^b \phi^b dx = 0, \quad \forall (\phi^a, \phi^b) \in U_n^0, \end{cases} \quad (2.75)$$

where \mathcal{U}_n^0 is defined in (2.20). Then,

$$\left\{ \begin{array}{l} \Phi_{(q_n^a, q_n^b)}^a \rightarrow 0 \text{ strongly in } (H^1(\Omega^a)), \quad \Phi_{(q_n^a, q_n^b)}^b \rightarrow 0 \text{ strongly in } (H^1(\Omega^b)), \\ \left(\frac{1}{h_n} \frac{\partial \Phi_{(q_n^a, q_n^b)}^a}{\partial x_1}, \frac{1}{h_n} \frac{\partial \Phi_{(q_n^a, q_n^b)}^a}{\partial x_2} \right) \rightarrow (0, 0) \text{ strongly in } (L^2(\Omega^a))^2, \\ \left(\frac{1}{h_n} \frac{\partial \Phi_{(q_n^a, q_n^b)}^b}{\partial x_2}, \frac{1}{h_n} \frac{\partial \Phi_{(q_n^a, q_n^b)}^b}{\partial x_3} \right) \rightarrow (0, 0) \text{ strongly in } (L^2(\Omega^b))^2, \end{array} \right. \quad (2.76)$$

and

$$\lim_n \left(\int_{\Omega^a} |D_n^a \Phi_{(q_n^a, q_n^b)}^a|^2 dx + \int_{\Omega^b} |D_n^b \Phi_{(q_n^a, q_n^b)}^b|^2 dx \right) = 0. \quad (2.77)$$

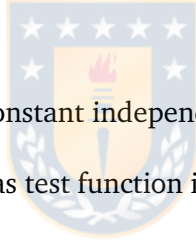

Proof. In this proof, C denotes any positive constant independent of $n \in \mathbb{N}$.

Choosing $(\phi^a, \phi^b) = (\Phi_{(q_n^a, q_n^b)}^a, \Phi_{(q_n^a, q_n^b)}^b)$ as test function in (2.75), applying Young inequality, and using (2.74) give

$$\|D_n^a \Phi_{(q_n^a, q_n^b)}^a\|_{(L^2(\Omega^a))^3} \leq C, \quad \|D_n^b \Phi_{(q_n^a, q_n^b)}^b\|_{(L^2(\Omega^b))^3} \leq C, \quad \forall n \in \mathbb{N}. \quad (2.78)$$

Consequently, taking into account the boundary conditions satisfied by $(\Phi_{(q_n^a, q_n^b)}^a, \Phi_{(q_n^a, q_n^b)}^b)$ and the trace theorem, one derives that

$$(\Phi_{(q_n^a, q_n^b)}^a, \Phi_{(q_n^a, q_n^b)}^b) \rightharpoonup (0, 0) \text{ weakly in } H^1(\Omega^a) \times H^1(\Omega^b), \quad (2.79)$$

and the existence of a subsequence of \mathbb{N} , still denotes by $\{n\}$ and (in possible dependence on the subsequence) $(\xi^a, \zeta^a) \in (L^2(\Omega^a))^2$ and $(\xi^b, \zeta^b) \in (L^2(\Omega^b))^2$ such that

$$\left(\frac{1}{h_n} \frac{\partial \Phi_{(q_n^a, q_n^b)}^a}{\partial x_1}, \frac{1}{h_n} \frac{\partial \Phi_{(q_n^a, q_n^b)}^a}{\partial x_2} \right) \rightharpoonup (\xi^a, \zeta^a) \text{ weakly in } (L^2(\Omega^a))^2, \quad (2.80)$$

$$\left(\frac{1}{h_n} \frac{\partial \Phi_{(q_n^a, q_n^b)}^b}{\partial x_2}, \frac{1}{h_n} \frac{\partial \Phi_{(q_n^a, q_n^b)}^b}{\partial x_3} \right) \rightharpoonup (\xi^b, \zeta^b) \text{ weakly in } (L^2(\Omega^b))^2. \quad (2.81)$$

Let us prove that

$$\int_{\Omega^a} \xi^a q_1^a dx = 0, \quad \int_{\Omega^a} \zeta^a q_2^a dx = 0, \quad \int_{\Omega^b} \xi^b q_2^b dx = 0, \quad \int_{\Omega^b} \zeta^b q_3^b dx = 0. \quad (2.82)$$

Indeed, let

$$g_n(x_3) = \sum_{i=0}^{n-1} \left(n \int_{\frac{i}{n}}^{\frac{i+1}{n}} q_1^a(t) dt \chi_{[\frac{i}{n}, \frac{i+1}{n}[}(x_3) \right), \quad x_3 \text{ a.e. in }]0, 1[, \quad \forall n \in \mathbb{N}.$$

It is well known that

$$g_n \rightarrow q_1^a \text{ strongly in } L^2(]0, 1[),$$

as n diverges. Consequently, taking also into account (2.80), one has

$$\begin{aligned} \int_{\Omega^a} \xi^a q_1^a dx &= \lim_n \int_{\Omega^a} \frac{1}{h_n} \frac{\partial \phi_{(q_n^a, q_n^b)}^a}{\partial x_1}(x) g_n(x_3) dx \\ &= \lim_n \sum_{i=0}^{n-1} \left(n \int_{\frac{i}{n}}^{\frac{i+1}{n}} q_1^a(t) dt \frac{1}{h_n} \int_{]-\frac{1}{2}, \frac{1}{2}[^2 \times]\frac{i}{n}, \frac{i+1}{n}[} \frac{\partial \phi_{(q_n^a, q_n^b)}^a}{\partial x_1}(x) dx \right) \end{aligned}$$

and the last integrals are zero due to the boundary condition on $\phi_{(q_n^a, q_n^b)}^a$. It is so proved the first equality in (2.82). Similarly, one proves the other ones.

Now (2.80), (2.81), and a l.s.c. argument provide

$$\lim_n \left(\int_{\Omega^a} \left| D_n^a \phi_{(q_n^a, q_n^b)}^a \right|^2 dx + \int_{\Omega^b} \left| D_n^a \phi_{(q_n^a, q_n^b)}^b \right|^2 dx \right) \quad (2.83)$$

$$\geq \int_{\Omega^a} |\xi^a|^2 dx + \int_{\Omega^a} |\zeta^a|^2 dx + \int_{\Omega^b} |\xi^b|^2 dx + \int_{\Omega^b} |\zeta^b|^2 dx, \quad (2.84)$$

while choosing $(\phi_{(q_n^a, q_n^b)}^a, \phi_{(q_n^a, q_n^b)}^b)$ as test functions in (2.75) and using (2.74), (2.79), (2.80), (2.81), and (2.82) provide

$$\begin{aligned} &\int_{\Omega^a} \left| D_n^a \phi_{(q_n^a, q_n^b)}^a \right|^2 dx + \int_{\Omega^b} \left| D_n^a \phi_{(q_n^a, q_n^b)}^b \right|^2 dx = \\ &\int_{\Omega^a} D_n^a \phi_{(q_n^a, q_n^b)}^a q_n^a dx + \int_{\Omega^a} D_n^b \phi_{(q_n^a, q_n^b)}^b q_n^b dx \rightarrow 0, \end{aligned} \quad (2.85)$$

as n diverges. Finally combining (2.84) and (2.85) implies

$$\xi^a = \zeta^a = 0 \text{ in } \Omega^a \text{ and } \xi^b = \zeta^b = 0 \text{ in } \Omega^b,$$

and convergences (2.79), (2.80), and (2.81) are strong. Note that also convergences in (2.80) and (2.81) hold true for the whole sequence, since the limits are uniquely identified. \square

2.5 The asymptotic behavior of problem (2.4)

2.5.1 The main result

Let

$$\begin{aligned} E : (q^a, q^b) = ((q_1^a, q_2^a, q_3^a), (q_1^b, q_2^b, q_3^b)) &\in (H^1([0, 1])^3 \times \left(H^1\left(\left[-\frac{1}{2}, \frac{1}{2}\right]\right)\right)^3 \rightarrow \\ &\int_0^1 \left(\left| \frac{dq^a}{dx_3} \right|^2 + \alpha (|q^a|^2 - 1)^2 + \eta (|q_1^a|^2 + |q_2^a|^2) + |q_3^a|^2 \right) dx_3 + \int_0^1 \left(\int_{]-\frac{1}{2}, \frac{1}{2}[}^2 f^a dx_1 dx_2 q^a \right) dx_3 \\ &+ \int_{-\frac{1}{2}}^{\frac{1}{2}} \left(\left| \frac{dq^b}{dx_1} \right|^2 + \alpha (|q^b|^2 - 1)^2 + |q_1^b|^2 + \eta (|q_2^b|^2 + |q_3^b|^2) \right) dx_1 + \int_{-\frac{1}{2}}^{\frac{1}{2}} \left(\int_{]-\frac{1}{2}, \frac{1}{2}[\times]-1, 0[} f^b dx_2 dx_3 q^b \right) dx_1, \end{aligned} \quad (2.86)$$

where f^a and f^b are defined in (2.30), and η in (2.35). Moreover, let

$$P = \left\{ (q^a, q^b) \in \left(H^1([0, 1])^3 \times \left(H^1\left(\left[-\frac{1}{2}, \frac{1}{2}\right]\right)\right)^3 : q^a(0) = q^b(0) \right\}. \quad (2.87)$$

The main result of this section is the following one.

THEOREM 2.1. *For every $n \in \mathbb{N}$, let (p_n^a, p_n^b) be a solution to (2.25), and let $(\phi_{(p_n^a, p_n^b)}^a, \phi_{(p_n^a, p_n^b)}^b)$ be the unique solution to (2.23) with $(p^a, p^b) = (p_n^a, p_n^b)$. Moreover, let E and P be defined by (2.86) and (2.87), respectively. Assume (2.30). Then, there exist an increasing sequence of positive integer numbers $\{n_i\}_{i \in \mathbb{N}}$ and (in possible dependence on the subsequence) $(p^a, p^b) \in P$ such that*

$$\begin{cases} p_{n_i}^a \rightarrow p^a & \text{strongly in } (H^1(\Omega^a))^3 \text{ and strongly in } (L^4(\Omega^a))^3, \\ p_{n_i}^b \rightarrow p^b & \text{strongly in } (H^1(\Omega^b))^3 \text{ and strongly in } (L^4(\Omega^b))^3, \end{cases} \quad (2.88)$$

$$\left\{ \begin{array}{l} \left(\frac{1}{h_n} \frac{\partial p_n^a}{\partial x_1}, \frac{1}{h_n} \frac{\partial p_n^a}{\partial x_2} \right) \rightarrow (0, 0) \text{ strongly in } (L^2(\Omega^a))^3 \times (L^2(\Omega^a))^3, \\ \left(\frac{1}{h_n} \frac{\partial p_n^b}{\partial x_2}, \frac{1}{h_n} \frac{\partial p_n^b}{\partial x_3} \right) \rightarrow (0, 0) \text{ strongly in } (L^2(\Omega^b))^3 \times (L^2(\Omega^b))^3, \end{array} \right. \quad (2.89)$$

$$\left\{ \begin{array}{l} \phi_{(p_{n_i}^a, p_{n_i}^b)}^a \rightarrow \int_0^{x_3} p_3^a(t) dt - \int_0^1 \left(\int_0^{x_3} p_3^a(t) dt \right) dx_3 \quad \text{strongly in } H^1(\Omega^a), \\ \phi_{(p_{n_i}^a, p_{n_i}^b)}^b \rightarrow \int_{-\frac{1}{2}}^{x_1} p_1^b(t) dt - \int_0^1 \left(\int_0^{x_3} p_3^a(t) dt \right) dx_3 - \int_{-\frac{1}{2}}^0 p_1^b(t) dt \quad \text{strongly in } H^1(\Omega^b), \\ \left(\frac{1}{h_n} \frac{\partial \phi_{(p_{n_i}^a, p_{n_i}^b)}^a}{\partial x_1}, \frac{1}{h_n} \frac{\partial \phi_{(p_{n_i}^a, p_{n_i}^b)}^a}{\partial x_2} \right) \rightarrow p_1^a D r + p_2^a D s \quad \text{strongly in } (L^2(\Omega^a))^2, \\ \left(\frac{1}{h_n} \frac{\partial \phi_{(p_{n_i}^a, p_{n_i}^b)}^b}{\partial x_2}, \frac{1}{h_n} \frac{\partial \phi_{(p_{n_i}^a, p_{n_i}^b)}^b}{\partial x_3} \right) \rightarrow p_2^b D \bar{r} + p_3^b D \bar{s} \quad \text{strongly in } (L^2(\Omega^b))^2, \end{array} \right. \quad (2.90)$$

where where r and s are the unique solutions to (2.31) and (2.32), respectively, \bar{r} and \bar{s} are defined by

$$\bar{r} = r \left(x_2, x_3 + \frac{1}{2} \right), \quad \bar{s} = s \left(x_2, x_3 + \frac{1}{2} \right), \text{ a.e. in } \left] -\frac{1}{2}, \frac{1}{2} \right[\times]0, 1[,$$

and (p^a, p^b) solves

$$E(p^a, p^b) = \min\{E((q^a, q^b)) : (q^a, q^b) \in P\}. \quad (2.91)$$

Moreover

$$\lim_n \frac{E_n((p_n^a, p_n^b))}{h_n^2} = E((p^a, p^b)). \quad (2.92)$$

2.5.2 A priori estimates on polarization

PROPOSITION 2.5.1. Assume (2.30). For every $n \in \mathbb{N}$, let (p_n^a, p_n^b) be a solution to (2.25). Then, there exists a constant c , independent of $n \in \mathbb{N}$, such that

$$\|p_n^a\|_{(L^4(\Omega^a))^3} \leq c, \quad \|p_n^b\|_{(L^4(\Omega^b))^3} \leq c, \quad \forall n \in \mathbb{N}, \quad (2.93)$$

$$\|D_n^a p_n^a\|_{(L^2(\Omega^a))^9} \leq c, \quad \|D_n^b p_n^b\|_{(L^2(\Omega^b))^9} \leq c, \quad \forall n \in \mathbb{N}. \quad (2.94)$$

Proof. Function 0 belonging to P_n gives

$$\begin{aligned}
& \int_{\Omega^a} \left(|D_n^a p_n^a|^2 + \alpha \left(|p_n^a|^4 - 2|p_n^a|^2 \right) + |D_n^a \phi_{(p_n^a, p_n^b)}^a|^2 \right) dx \\
& + \int_{\Omega^b} \left(|D_n^b p_n^b|^2 + \alpha \left(|p_n^b|^4 - 2|p_n^b|^2 \right) + |D_n^b \phi_{(p_n^a, p_n^b)}^b|^2 \right) dx \\
& \leq \frac{1}{2} \int_{\Omega^a} \left(|f_n^a|^2 + |p_n^a|^2 \right) dx + \frac{1}{2} \int_{\Omega^b} \left(|f_n^b|^2 + |p_n^b|^2 \right) dx, \quad \forall n \in \mathbb{N}.
\end{aligned} \tag{2.95}$$

Estimates (2.95) implies

$$\begin{aligned}
& \int_{\Omega^a} \alpha \left(|p_n^a|^4 - \left(2 + \frac{1}{2\alpha} \right) |p_n^a|^2 \right) dx + \int_{\Omega^b} \alpha \left(|p_n^b|^4 - \left(2 + \frac{1}{2\alpha} \right) |p_n^b|^2 \right) dx \\
& \leq \frac{1}{2} \int_{\Omega^a} |f_n^a|^2 dx + \frac{1}{2} \int_{\Omega^b} |f_n^b|^2 dx, \quad \forall n \in \mathbb{N},
\end{aligned}$$

which gives

$$\begin{aligned}
& \int_{\Omega^a} \alpha \left(|p_n^a|^2 - \left(1 + \frac{1}{4\alpha} \right) \right)^2 dx + \int_{\Omega^b} \alpha \left(|p_n^b|^2 - \left(1 + \frac{1}{4\alpha} \right) \right)^2 dx \\
& \leq \alpha \left(1 + \frac{1}{4\alpha} \right)^2 \left(|\Omega^a| + |\Omega^b| \right) + \frac{1}{2} \int_{\Omega^a} |f_n^a|^2 dx + \frac{1}{2} \int_{\Omega^b} |f_n^b|^2 dx, \quad \forall n \in \mathbb{N}.
\end{aligned} \tag{2.96}$$

Then the estimates in (2.93) follow from (2.96) and (2.30). The estimates in (2.94) follow from (2.95), (2.30), (2.93), and the continuous embedding of L^4 into L^2 . \square

By arguing as in [42], Proposition 2.5.1 provides the following result.

COROLLARY 2.1. *Assume (2.30). For every $n \in \mathbb{N}$, let (p_n^a, p_n^b) be a solution to (2.25). Let P be defined in (2.87). Then there exist a subsequence of \mathbb{N} , still denoted by $\{n\}$, and (in possible dependence on the subsequence) $(p^a, p^b) \in P$ such that*

$$\begin{cases} p_n^a \rightharpoonup p^a \text{ weakly in } (H^1(\Omega^a))^3 \text{ and strongly in } (L^4(\Omega^a))^3, \\ p_n^b \rightharpoonup p^b \text{ weakly in } (H^1(\Omega^b))^3 \text{ and strongly in } (L^4(\Omega^b))^3. \end{cases} \tag{2.97}$$

2.5.3 The proof of Theorem 2.1

Proposition 2.5.1 and Corollary 2.1 assert that there exist a subsequence of \mathbb{N} , still denoted by $\{n\}$, and (in possible dependence on the subsequence) $(p^a, p^b) \in P$ and $(z^a, z^b) \in (L^2(\Omega^a))^6 \times (L^2(\Omega^b))^6$ satisfying (2.97) and

$$\left\{ \begin{array}{l} \left(\frac{1}{h_n} \frac{\partial p_n^a}{\partial x_1}, \frac{1}{h_n} \frac{\partial p_n^a}{\partial x_2} \right) \rightharpoonup z^a \text{ weakly in } (L^2(\Omega^a))^6, \\ \left(\frac{1}{h_n} \frac{\partial p_n^b}{\partial x_2}, \frac{1}{h_n} \frac{\partial p_n^b}{\partial x_3} \right) \rightharpoonup z^b \text{ weakly in } (L^2(\Omega^b))^6. \end{array} \right. \quad (2.98)$$

Limits in (2.90) follow from (2.97), thanks to Proposition 2.4.2.

Let $(q^a, q^b) \in P$ be such that for each $i = 1, 2, 3$ $(q_i^a, q_i^b) \in U_{\text{reg}}$, where U_{reg} is defined in (2.37). As in (2.53)-(2.54), working on each couple (q_i^a, q_i^b) , one can build a sequence $\{(q_n^a, q_n^b)\}_{n \in \mathbb{N}}$, with $(q_n^a, q_n^b) \in P_n$, such that, thanks also to (2.30) and Proposition 2.4.2,

$$\lim_n \frac{E_n((q_n^a, q_n^b))}{h_n^2} = E((q^a, q^b)).$$

Consequently, recalling that (p_n^a, p_n^b) is a solution to (2.25) an using Proposition 2.4.1, one has

$$\overline{\lim}_n \frac{E_n((p_n^a, p_n^b))}{h_n^2} \leq E((q^a, q^b)), \quad \forall (q^a, q^b) \in P. \quad (2.99)$$

On the other side, (2.30), (2.97), (2.98), a l.s.c. argument, and Proposition 2.4.2 ensure that

$$\int_{\Omega^a} |z^a|^2 dx + \int_{\Omega^b} |z^b|^2 dx + E((p^a, p^b)) \leq \underline{\lim}_n \frac{E_n((p_n^a, p_n^b))}{h_n^2}. \quad (2.100)$$

Combining (2.100) and (2.99) with $(q^a, q^b) = (p^a, p^b)$ provides

$$z^a = 0 \text{ a.e. in } \Omega^a, \quad z^b = 0 \text{ a.e. in } \Omega^b. \quad (2.101)$$

Then, (2.91) and (2.92) follow again from and (2.99), (2.100), and (2.101).

To obtain (2.88) and (2.89), it remain to prove that convergences in (2.97) and (2.98) are strong.

At first note that (2.92), (2.97), Proposition 2.4.2, and (2.30) give

$$\lim_n \left(\int_{\Omega^a} |D_n^a p_n^a|^2 dx + \int_{\Omega^b} |D_n^b p_n^b|^2 dx \right) = \int_{\Omega^a} \left| \frac{dp^a}{dx_3} \right|^2 dx + \int_{\Omega^b} \left| \frac{dp^b}{dx_1} \right|^2 dx,$$

which implies (2.89) and

$$\frac{\partial p_n^a}{\partial x_3} \rightarrow \frac{dp^a}{dx_3} \text{ strongly in } L^2(\Omega^a), \quad \frac{\partial p_n^b}{\partial x_1} \rightarrow \frac{dp^b}{dx_1} \text{ strongly in } L^2(\Omega^b), \quad (2.102)$$

thanks to (2.97), (2.98), and (2.101). Eventually, (2.88) follows from (2.89), (2.97), and (2.102). \square

2.6 The asymptotic behavior of problem (2.5)

2.6.1 The main result

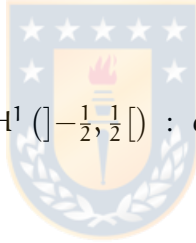

Set

$$\begin{aligned} \tilde{\mathcal{P}} = \{ & (q_3^a, q_1^b) \in H^1([0, 1]) \times H^1\left(\left[-\frac{1}{2}, \frac{1}{2}\right]\right) : q_3^a(1) = 0, q_1^b(\pm \frac{1}{2}) = 0, \\ & q_3^a(0) = q_1^b(0) = 0\}. \end{aligned} \quad (2.103)$$

The main result of this section is the following one.

THEOREM 2.2. *For every $n \in \mathbb{N}$, let (p_n^a, p_n^b) be a solution to (2.26), and let $(\phi_{(p_n^a, p_n^b)}^a, \phi_{(p_n^a, p_n^b)}^b)$ be the unique solution to (2.23) with $(p^a, p^b) = (p_n^a, p_n^b)$. Moreover, let E and $\tilde{\mathcal{P}}$ be defined by (2.86) and (2.103), respectively. Assume (2.30). Then there exist an increasing sequence of positive integer numbers $\{n_i\}_{i \in \mathbb{N}}$ and (in possible dependence on the subsequence) $(p_3^a, p_1^b) \in \tilde{\mathcal{P}}$ such that*

$$\begin{cases} p_{n_i}^a \rightarrow (0, 0, p_3^a) \text{ strongly in } (H^1(\Omega^a))^3 \text{ and strongly in } (L^4(\Omega^a))^3, \\ p_{n_i}^b \rightarrow (p_1^b, 0, 0) \text{ strongly in } (H^1(\Omega^b))^3 \text{ and strongly in } (L^4(\Omega^b))^3, \end{cases} \quad (2.104)$$

$$\begin{cases} \left(\frac{1}{h_n} \frac{\partial p_n^a}{\partial x_1}, \frac{1}{h_n} \frac{\partial p_n^a}{\partial x_2} \right) \rightarrow (0, 0) \text{ strongly in } (L^2(\Omega^a))^3 \times (L^2(\Omega^a))^3, \\ \left(\frac{1}{h_n} \frac{\partial p_n^b}{\partial x_2}, \frac{1}{h_n} \frac{\partial p_n^b}{\partial x_3} \right) \rightarrow (0, 0) \text{ strongly in } (L^2(\Omega^b))^3 \times (L^2(\Omega^b))^3, \end{cases} \quad (2.105)$$

$$\left\{ \begin{array}{l} \Phi_{(p_{n_i}^a, p_{n_i}^b)}^a \rightarrow \int_0^{x_3} p_3^a(t) dt - \int_0^1 \left(\int_0^{x_3} p_3^a(t) dt \right) dx_3 \quad \text{strongly in } H^1(\Omega^a), \\ \Phi_{(p_{n_i}^a, p_{n_i}^b)}^b \rightarrow \int_{-\frac{1}{2}}^{x_1} p_1^b(t) dt - \int_0^1 \left(\int_0^{x_3} p_3^a(t) dt \right) dx_3 - \int_{-\frac{1}{2}}^0 p_1^b(t) dt \quad \text{strongly in } H^1(\Omega^b), \\ \left(\frac{1}{h_n} \frac{\partial \Phi_{(p_{n_i}^a, p_{n_i}^b)}^a}{\partial x_1}, \frac{1}{h_n} \frac{\partial \Phi_{(p_{n_i}^a, p_{n_i}^b)}^a}{\partial x_2} \right) \rightarrow (0, 0) \quad \text{strongly in } (L^2(\Omega^a))^2, \\ \left(\frac{1}{h_n} \frac{\partial \Phi_{(p_{n_i}^a, p_{n_i}^b)}^b}{\partial x_2}, \frac{1}{h_n} \frac{\partial \Phi_{(p_{n_i}^a, p_{n_i}^b)}^b}{\partial x_3} \right) \rightarrow (0, 0) \quad \text{strongly in } (L^2(\Omega^b))^2, \end{array} \right.$$

where (p_3^a, p_1^b) solves

$$E(((0, 0, p_3^a), (p_1^b, 0, 0))) = \min \left\{ E(((0, 0, q_3^a), (q_1^b, 0, 0))) : (q_3^a, q_1^b) \in \tilde{P} \right\}, \quad (2.106)$$

Moreover

$$\lim_n \frac{E_n((p_n^a, p_n^b))}{h_n^2} = E(((0, 0, p_3^a), (p_1^b, 0, 0))). \quad (2.107)$$

2.6.2 A priori estimates on polarization

Arguing as in the proof of Proposition 2.5.1 gives the following estimate result.

PROPOSITION 2.6.1. *Assume (2.30). For every $n \in \mathbb{N}$, let (p_n^a, p_n^b) be a solution to (2.26). Then, there exists a constant c , independent of n , such that*

$$\|p_n^a\|_{(L^4(\Omega^a))^3} \leq c, \quad \|p_n^b\|_{(L^4(\Omega^b))^3} \leq c, \quad \forall n \in \mathbb{N}, \quad (2.108)$$

$$\|D_n^a p_n^a\|_{(L^2(\Omega^a))^9} \leq c, \quad \|D_n^b p_n^b\|_{(L^2(\Omega^b))^9} \leq c, \quad \forall n \in \mathbb{N}. \quad (2.109)$$

COROLLARY 2.2. *Assume (2.30). For every $n \in \mathbb{N}$, let (p_n^a, p_n^b) be a solution to (2.26). Let \tilde{P} be defined in (2.103). Then there exist a subsequence of \mathbb{N} , still denoted by $\{n\}$, and (in possible dependence on the*

subsequence) $(p_3^a, p_1^b) \in \tilde{\mathcal{P}}$ such that

$$\begin{cases} p_n^a \rightharpoonup (0, 0, p_3^a) & \text{weakly in } (H^1(\Omega^a))^3 \text{ and strongly in } (L^4(\Omega^a))^3, \\ p_n^b \rightharpoonup (p_1^b, 0, 0) & \text{weakly in } (H^1(\Omega^b))^3 \text{ and strongly in } (L^4(\Omega^b))^3. \end{cases} \quad (2.110)$$

Proof. Proposition 2.6.1 ensures that there exist a subsequence of \mathbb{N} , still denoted by $\{n\}$, and (in possible dependence on the subsequence) $(p_1^a, p_2^a, p_3^a) \in (H^1(\Omega^a))^3$ independent of x_1 and x_2 , and $(p_1^b, p_2^b, p_3^b) \in (H^1(\Omega^b))^3$ independent of x_2 and x_3 such that

$$\begin{cases} p_n^a \rightharpoonup (p_1^a, p_2^a, p_3^a) & \text{weakly in } (H^1(\Omega^a))^3 \text{ and strongly in } (L^4(\Omega^a))^3, \\ p_n^b \rightharpoonup (p_1^b, p_2^b, p_3^b) & \text{weakly in } (H^1(\Omega^b))^3 \text{ and strongly in } (L^4(\Omega^b))^3, \end{cases} \quad (2.111)$$

and $(p_1^a, p_2^a, p_3^a)\nu^a = 0$ on $\partial\Omega^a \setminus (]-\frac{1}{2}, \frac{1}{2}[^2 \times \{0\})$, $(p_1^b, p_2^b, p_3^b)\nu^b = 0$ on $\partial\Omega^b \setminus (]-\frac{1}{2}, \frac{1}{2}[^2 \times \{0\})$. In particular, this implies

$$p_1^a = p_2^a = 0 \text{ in } \Omega^a \quad (2.112)$$

$$p_3^a(1) = 0,$$

$$p_2^b = p_3^b = 0 \text{ in } \Omega^b, \quad (2.113)$$

$$p_1^b(\pm\frac{1}{2}) = 0.$$

By arguing as in [42], one proves that

$$(p_1^a(0), p_2^a(0), p_3^a(0)) = (p_1^b(0), p_2^b(0), p_3^b(0)).$$

Consequently, by virtue of (2.112) and (2.113), one has

$$p_3^a(0) = 0 = p_1^b(0). \quad (2.114)$$

□

2.6.3 A convergence result for problem (2.41)

Proposition 2.4.2 provides the following result.

PROPOSITION 2.6.2. *Let $\{(q_n^a, q_n^b)\}_{n \in \mathbb{N}} \subset (L^2(\Omega^a))^3 \times (L^2(\Omega^b))^3$, and let $(q_3^a, q_1^b) \in L^2(\Omega^a) \times L^2(\Omega^b)$ be such that q_3^a is independent of (x_1, x_2) , q_1^b is independent of (x_2, x_3) and*

$$(q_n^a, q_n^b) \rightarrow ((0, 0, q_3^a), (q_1^b, 0, 0)) \text{ strongly in } (L^2(\Omega^a))^3 \times (L^2(\Omega^b))^3. \quad (2.115)$$

Moreover, for $n \in \mathbb{N}$ let $(\phi_{(q_n^a, q_n^b)}^a, \phi_{(q_n^a, q_n^b)}^b)$ be the unique solution to (2.41). Then,

$$\left\{ \begin{array}{l} \phi_{(q_n^a, q_n^b)}^a \rightarrow \int_0^{x_3} q_3^a(t) dt - \int_0^1 \left(\int_0^{x_3} q_3^a(t) dt \right) dx_3 \quad \text{strongly in } (H^1(\Omega^a)), \\ \phi_{(q_n^a, q_n^b)}^b \rightarrow \int_{-\frac{1}{2}}^{x_1} q_1^b(t) dt - \int_0^1 \left(\int_0^{x_3} q_3^a(t) dt \right) dx_3 - \int_{-\frac{1}{2}}^0 q_1^b(t) dt \quad \text{strongly in } (H^1(\Omega^b)), \\ \left(\frac{1}{h_n} \frac{\partial \phi_{(q_n^a, q_n^b)}^a}{\partial x_1}, \frac{1}{h_n} \frac{\partial \phi_{(q_n^a, q_n^b)}^a}{\partial x_2} \right) \rightarrow (0, 0) \quad \text{strongly in } (L^2(\Omega^a))^2, \\ \left(\frac{1}{h_n} \frac{\partial \phi_{(q_n^a, q_n^b)}^b}{\partial x_2}, \frac{1}{h_n} \frac{\partial \phi_{(q_n^a, q_n^b)}^b}{\partial x_3} \right) \rightarrow (0, 0) \quad \text{strongly in } (L^2(\Omega^b))^2. \end{array} \right. \quad (2.116)$$

2.6.4 The proof of Theorem 2.2

Before proving Theorem 2.2, let us recall an evident result.

PROPOSITION 2.6.3. *Let \tilde{P} and P_{reg} be defined in (2.103) and (2.117), respectively. Then P_{reg} is dense in \tilde{P} where*

$$P_{reg} = C_0^1([0, 1[) \times C_0^1\left(1 - \frac{1}{2}, 0 \cup]0, \frac{1}{2}[\right) \quad (2.117)$$

Now we have all tools to prove Theorem 2.2. In what follows, $p_{n,i}^a$ (resp. $p_{n,i}^b$) denotes the i -th component, $i = 1, 2, 3$, of p_n^a (resp. p_n^b). Proposition 2.6.1 and Corollary 2.2 assert that there exist a subsequence of \mathbb{N} , still denoted by $\{n\}$, and (in possible dependence on the subsequence) $(p_3^a, p_1^b) \in \tilde{P}$

satisfying (2.110) and $(z^a, z^b) \in (L^2(\Omega^a))^6 \times (L^2(\Omega^b))^6$ satisfying

$$\begin{cases} \left(\frac{1}{h_n} \frac{\partial p_n^a}{\partial x_1}, \frac{1}{h_n} \frac{\partial p_n^a}{\partial x_2} \right) \rightharpoonup z^a \text{ weakly in } (L^2(\Omega^a))^6, \\ \left(\frac{1}{h_n} \frac{\partial p_n^b}{\partial x_2}, \frac{1}{h_n} \frac{\partial p_n^b}{\partial x_3} \right) \rightharpoonup z^b \text{ weakly in } (L^2(\Omega^b))^6. \end{cases} \quad (2.118)$$

The next step is devoted to identifying p_3^a, p_1^b, z^a , and z^b . To this end, let

$$v = \begin{cases} (0, 0, q_3^a), & \text{in } \Omega^a, \\ (q_1^b, 0, 0), & \text{in } \Omega^b, \end{cases}$$

with $(q_3^a, q_1^b) \in P_{\text{reg}}$. Then v belongs to P_n , for n large enough. Consequently,

$$\frac{1}{h_n^2} E_n((p_n^a, p_n^b)) \leq \frac{1}{h_n^2} E_n(((0, 0, q_3^a), (q_1^b, 0, 0))), \text{ for } n \text{ large enough.} \quad (2.119)$$

Then, passing to the limit in (2.119), as n diverges, and using (2.30), (2.110), (2.118), Proposition 2.6.2, and a l.s.c. argument imply

$$\begin{aligned} & \int_{\Omega^a} \left(|z^a|^2 + \left| \frac{dp_3^a}{dx_3} \right|^2 \right) dx + \int_0^1 \left(\alpha(|p_3^a|^2 - 1)^2 + |p_3^a|^2 \right) dx_3 + \int_0^1 \left(\int_{]-\frac{1}{2}, \frac{1}{2}[}^2 f_3^a dx_1 dx_2 p_3^a \right) dx_3 \\ & + \int_{\Omega^b} \left(|z^b|^2 + \left| \frac{dp_1^b}{dx_1} \right|^2 \right) dx + \int_{-\frac{1}{2}}^{\frac{1}{2}} \left(\alpha(|p_1^b|^2 - 1)^2 + |p_1^b|^2 \right) dx_1 + \int_{-\frac{1}{2}}^{\frac{1}{2}} \left(\int_{]-\frac{1}{2}, \frac{1}{2}[\times [-1, 0]} f_1^b dx_2 dx_3 p_1^b \right) dx_1 \\ & \leq \liminf_n \frac{E_n((p_n^a, p_n^b))}{h_n^2} \leq \overline{\lim}_n \frac{E_n((p_n^a, p_n^b))}{h_n^2} \leq \liminf_n \frac{E_n(((0, 0, q_3^a), (q_1^b, 0, 0)))}{h_n^2} \\ & = E(((0, 0, q_3^a), (q_1^b, 0, 0))). \end{aligned}$$

Then, by virtue of Proposition 2.6.3,

$$\begin{aligned} & \int_{\Omega^a} |z^a|^2 dx + \int_{\Omega^b} |z^b|^2 dx + E(((0, 0, p_3^a), (p_1^b, 0, 0))) \leq \liminf_n \frac{E_n((p_n^a, p_n^b))}{h_n^2} \\ & \leq \overline{\lim}_n \frac{E_n((p_n^a, p_n^b))}{h_n^2} \leq E(((0, 0, q_3^a), (q_1^b, 0, 0))), \quad \forall (q_3^a, q_1^b) \in P, \end{aligned} \quad (2.120)$$

which implies that $z^a = 0, z^b = 0, (p_3^a, p_1^b)$ solves (2.106), convergence (2.107) holds true, and

convergences in (2.110) and (2.118) are strong. □

2.7 The asymptotic behavior of problem (2.6)

2.7.1 The main result

Set

$$P^* = \left\{ (q_3^a, q_3^b) \in H^1([0, 1]) \times H^1\left(-\frac{1}{2}, \frac{1}{2}\right) : q_3^a(0) = q_3^b(0) \right\}. \quad (2.121)$$

The main result of this section is the following one.

THEOREM 2.3. *For every $n \in \mathbb{N}$, let (p_n^a, p_n^b) be a solution to (2.27), and let $(\phi_{(p_n^a, p_n^b)}^a, \phi_{(p_n^a, p_n^b)}^b)$ be the unique solution to (2.23) with $(p^a, p^b) = (p_n^a, p_n^b)$. Moreover, let E and P^* be defined by (2.86) and (2.121), respectively. Assume (2.30). Then there exist an increasing sequence of positive integer numbers $\{n_i\}_{i \in \mathbb{N}}$ and (in possible dependence on the subsequence) $(p_3^a, p_3^b) \in P^*$ such that*

$$\begin{cases} p_{n_i}^a \rightarrow (0, 0, p_3^a) & \text{strongly in } (H^1(\Omega^a))^3 \text{ and strongly in } (L^4(\Omega^a))^3, \\ p_{n_i}^b \rightarrow (0, 0, p_3^b) & \text{strongly in } (H^1(\Omega^b))^3 \text{ and strongly in } (L^4(\Omega^b))^3, \end{cases} \quad (2.122)$$

$$\begin{cases} \left(\frac{1}{h_n} \frac{\partial p_n^a}{\partial x_1}, \frac{1}{h_n} \frac{\partial p_n^a}{\partial x_2} \right) \rightarrow (0, 0) & \text{strongly in } (L^2(\Omega^a))^3 \times (L^2(\Omega^a))^3, \\ \left(\frac{1}{h_n} \frac{\partial p_n^b}{\partial x_2}, \frac{1}{h_n} \frac{\partial p_n^b}{\partial x_3} \right) \rightarrow (0, 0) & \text{strongly in } (L^2(\Omega^b))^3 \times (L^2(\Omega^b))^3, \end{cases} \quad (2.123)$$

$$\left\{ \begin{array}{l}
\Phi_{(p_{n_i}^a, p_{n_i}^b)}^a \rightarrow \int_0^{x_3} p_3^a(t) dt - \int_0^1 \left(\int_0^{x_3} p_3^a(t) dt \right) dx_3 \quad \text{strongly in } H^1(\Omega^a), \\
\Phi_{(p_{n_i}^a, p_{n_i}^b)}^b \rightarrow - \int_0^1 \left(\int_0^{x_3} p_3^a(t) dt \right) dx_3 \quad \text{strongly in } H^1(\Omega^b), \\
\left(\frac{1}{h_n} \frac{\partial \Phi_{(p_{n_i}^a, p_{n_i}^b)}^a}{\partial x_1}, \frac{1}{h_n} \frac{\partial \Phi_{(p_{n_i}^a, p_{n_i}^b)}^a}{\partial x_2} \right) \rightarrow (0, 0) \quad \text{strongly in } (L^2(\Omega^a))^2, \\
\left(\frac{1}{h_n} \frac{\partial \Phi_{(p_{n_i}^a, p_{n_i}^b)}^b}{\partial x_2}, \frac{1}{h_n} \frac{\partial \Phi_{(p_{n_i}^a, p_{n_i}^b)}^b}{\partial x_3} \right) \rightarrow p_3^b D \bar{s} \quad \text{strongly in } (L^2(\Omega^b))^2,
\end{array} \right. \quad (2.124)$$

where s is the unique solutions to (2.32), \bar{s} is defined by

$$\bar{s} = s \left(x_2, x_3 + \frac{1}{2} \right), \text{ a.e. in } \left] -\frac{1}{2}, \frac{1}{2} [\times] 0, 1 [,$$

and (p_3^a, p_3^b) solves

$$E(((0, 0, p_3^a), (0, 0, p_3^b))) = \min \left\{ E(((0, 0, q_3^a), (0, 0, q_3^b))) : (q_3^a, q_3^b) \in P^* \right\}, \quad (2.125)$$

Moreover

$$\lim_n \frac{E_n((p_n^a, p_n^b))}{h_n^2} = E(((0, 0, p_3^a), (0, 0, p_3^b))). \quad (2.126)$$

2.7.2 A priori estimates on polarization

Arguing as in Proposition 2.5.1 provides that

PROPOSITION 2.7.1. *Assume (2.30). For every $n \in \mathbb{N}$, let (p_n^a, p_n^b) be a solution to (2.27). Then, there exists a constant c such that*

$$\|p_n^a\|_{(L^4(\Omega^a))^3} \leq c, \quad \|p_n^b\|_{(L^4(\Omega^b))^3} \leq c, \quad \forall n \in \mathbb{N}, \quad (2.127)$$

$$\|D_n^a p_n^a\|_{(L^2(\Omega^a))^9} \leq c, \quad \|D_n^b p_n^b\|_{(L^2(\Omega^b))^9} \leq c, \quad \forall n \in \mathbb{N}. \quad (2.128)$$

COROLLARY 2.3. *Assume (2.30). For every $n \in \mathbb{N}$, let (p_n^a, p_n^b) be a solution to (2.27). Let P^* be defined*

in (2.121). Then there exist a subsequence of \mathbb{N} , still denoted by $\{n\}$, and (in possible dependence on the subsequence) $(p_3^a, p_3^b) \in P^*$ such that

$$\begin{cases} p_n^a \rightharpoonup (0, 0, p_3^a) & \text{weakly in } (H^1(\Omega^a))^3 \text{ and strongly in } (L^4(\Omega^a))^3, \\ p_n^b \rightharpoonup (0, 0, p_3^b) & \text{weakly in } (H^1(\Omega^b))^3 \text{ and strongly in } (L^4(\Omega^b))^3. \end{cases} \quad (2.129)$$

Proof. Proposition 2.7.1 ensures that there exist a subsequence of \mathbb{N} , still denoted by $\{n\}$, and (in possible dependence on the subsequence) $(p_1^a, p_2^a, p_3^a) \in (H^1(\Omega^a))^3$ independent of x_1 and x_2 , and $(p_1^b, p_2^b, p_3^b) \in (H^1(\Omega^b))^3$ independent of x_2 and x_3 such that

$$\begin{cases} p_n^a \rightharpoonup (p_1^a, p_2^a, p_3^a) & \text{weakly in } (H^1(\Omega^a))^3 \text{ and strongly in } (L^4(\Omega^a))^3, \\ p_n^b \rightharpoonup (p_1^b, p_2^b, p_3^b) & \text{weakly in } (H^1(\Omega^b))^3 \text{ and strongly in } (L^4(\Omega^b))^3, \end{cases} \quad (2.130)$$

and $(p_1^a, p_2^a, p_3^a) // e_3$ on $\partial\Omega^a \setminus (] - \frac{1}{2}, \frac{1}{2}[^2 \times \{0\})$, $(p_1^b, p_2^b, p_3^b) // e_3$ on $\partial\Omega^b \setminus (] - \frac{1}{2}, \frac{1}{2}[^2 \times \{0\})$. In particular, this implies

$$p_1^a = p_2^a = 0 \text{ in } \Omega^a, \quad (2.131)$$

$$p_1^b = p_2^b = 0 \text{ in } \Omega^b. \quad (2.132)$$

By arguing as in [42], one proves that

$$(p_1^a(0), p_2^a(0), p_3^a(0)) = (p_1^b(0), p_2^b(0), p_3^b(0)).$$

Consequently, one has

$$p_3^a(0) = p_3^b(0). \quad (2.133)$$

□

2.7.3 A convergence result for problem (2.23)

Proposition 2.4.2 provides the following result.

PROPOSITION 2.7.2. *Let $\{(q_n^a, q_n^b)\}_{n \in \mathbb{N}} \subset (L^2(\Omega^a))^3 \times (L^2(\Omega^b))^3$, and let $(q_3^a, q_3^b) \in L^2(\Omega^a) \times L^2(\Omega^b)$ be such that q_3^a is independent of (x_1, x_2) , q_3^b is independent of (x_2, x_3) and*

$$(q_n^a, q_n^b) \rightarrow ((0, 0, q_3^a), (0, 0, q_3^b)) \text{ strongly in } (L^2(\Omega^a))^3 \times (L^2(\Omega^b))^3. \quad (2.134)$$

Moreover, for $n \in \mathbb{N}$ let $(\phi_{(q_n^a, q_n^b)}^a, \phi_{(q_n^a, q_n^b)}^b)$ be the unique solution to (2.41) Then,

$$\left\{ \begin{array}{ll} \phi_{(q_n^a, q_n^b)}^a \rightarrow \int_0^{x_3} q_3^a(t) dt - \int_0^1 \left(\int_0^{x_3} q_3^a(t) dt \right) dx_3 & \text{strongly in } (H^1(\Omega^a)), \\ \phi_{(q_n^a, q_n^b)}^b \rightarrow - \int_0^1 \left(\int_0^{x_3} q_3^a(t) dt \right) dx_3 & \text{strongly in } (H^1(\Omega^b)), \\ \left(\frac{1}{h_n} \frac{\partial \phi_{(q_n^a, q_n^b)}^a}{\partial x_1}, \frac{1}{h_n} \frac{\partial \phi_{(q_n^a, q_n^b)}^a}{\partial x_2} \right) \rightarrow (0, 0) & \text{strongly in } (L^2(\Omega^a))^2, \\ \left(\frac{1}{h_n} \frac{\partial \phi_{(q_n^a, q_n^b)}^b}{\partial x_2}, \frac{1}{h_n} \frac{\partial \phi_{(q_n^a, q_n^b)}^b}{\partial x_3} \right) \rightarrow q_3^b D\bar{s} & \text{strongly in } (L^2(\Omega^b))^2, \end{array} \right. \quad (2.135)$$

and

$$\lim_n \left(\int_{\Omega^a} |D_n^a \phi_{(q_n^a, q_n^b)}^a|^2 dx + \int_{\Omega^b} |D_n^a \phi_{(q_n^a, q_n^b)}^b|^2 dx \right) = \int_0^1 |q_3^a|^2 dx_3 + \eta \int_{-\frac{1}{2}}^{\frac{1}{2}} |q_3^b|^2 dx_1. \quad (2.136)$$

where s is the unique solutions to (2.32), \bar{s} is defined by

$$\bar{s} = s \left(x_2, x_3 + \frac{1}{2} \right), \text{ a.e. in } \left] -\frac{1}{2}, \frac{1}{2} \right[\times]0, 1[,$$

and η is defined in (2.35).

2.7.4 Proof of Theorem 2.3

We sketch the proof. Proposition 2.7.1 and Corollary 2.3 assert that there exist a subsequence of \mathbb{N} , still denoted by $\{n\}$, and (in possible dependence on the subsequence) $(p_n^a, p_n^b) \in P^*$ and $(z^a, z^b) \in (L^2(\Omega^a))^6 \times (L^2(\Omega^b))^6$ satisfying (2.129) and

$$\left\{ \begin{array}{ll} \left(\frac{1}{h_n} \frac{\partial p_n^a}{\partial x_1}, \frac{1}{h_n} \frac{\partial p_n^a}{\partial x_2} \right) \rightharpoonup z^a & \text{weakly in } (L^2(\Omega^a))^6, \\ \left(\frac{1}{h_n} \frac{\partial p_n^b}{\partial x_2}, \frac{1}{h_n} \frac{\partial p_n^b}{\partial x_3} \right) \rightharpoonup z^b & \text{weakly in } (L^2(\Omega^b))^6. \end{array} \right. \quad (2.137)$$

Let U_{reg} be defined in (2.37) and let $(q_3^a, q_3^b) \in U_{\text{reg}}$. As in (2.53)-(2.54), one can build a sequence $\{(q_n^a, q_n^b)\}_{n \in \mathbb{N}}$, with $((0, 0, q_n^a), (0, 0, q_n^b)) \in P_n$, for each $n \in \mathbb{N}$, such that, thanks also to (2.30) and Proposition 2.7.2,

$$\varliminf_n \frac{E_n \left(((0, 0, q_n^a), (0, 0, q_n^b)) \right)}{h_n^2} = E \left(((0, 0, q_3^a), (0, 0, q_3^b)) \right).$$

Consequently, by virtue of Proposition 2.4.1, one has

$$\varliminf_n \frac{E_n \left((p_n^a, p_n^b) \right)}{h_n^2} \leq E \left(((0, 0, q_3^a), (0, 0, q_3^b)) \right), \quad \forall (q_3^a, q_3^b) \in \tilde{P}. \quad (2.138)$$

On the other side, (2.30), (2.129), (2.137), a l.s.c. argument, and Proposition 2.7.2 ensure that

$$\int_{\Omega^a} |z^a|^2 dx \int_{\Omega^b} |z^b|^2 dx + E \left(((0, 0, p_3^a), (0, 0, p_3^b)) \right) \leq \varliminf_n \frac{E_n \left((p_n^a, p_n^b) \right)}{h_n^2} \quad (2.139)$$

Finally, combining (2.138) and (2.139) completes the proof, as usual. \square

2.8 The asymptotic behavior of problem (2.15)

2.8.1 The main result

THEOREM 2.4. *For every $n \in \mathbb{N}$, let (p_n^a, p_n^b) be a solution to (2.28), and let $(\phi_{(p_n^a, p_n^b)}^a, \phi_{(p_n^a, p_n^b)}^b)$ be the unique solution to (2.23) with $(p^a, p^b) = (p_n^a, p_n^b)$. Moreover, let (2.86) and \tilde{P} be defined by (2.86) and (2.103), respectively. Assume (2.30). Then there exist an increasing sequence of positive integer numbers $\{n_i\}_{i \in \mathbb{N}}$ and (in possible dependence on the subsequence) $(p_3^a, p_1^b) \in \tilde{P}$ such that*

$$\begin{cases} p_{n_i}^a \rightarrow (0, 0, p_3^a) & \text{strongly in } (H^1(\Omega^a))^3 \text{ and strongly in } (L^4(\Omega^a))^3, \\ p_{n_i}^b \rightarrow (p_1^b, 0, 0) & \text{strongly in } (H^1(\Omega^b))^3 \text{ and strongly in } (L^4(\Omega^b))^3, \end{cases} \quad (2.140)$$

$$\begin{cases} \left(\frac{1}{h_n} \frac{\partial p_n^a}{\partial x_1}, \frac{1}{h_n} \frac{\partial p_n^a}{\partial x_2} \right) \rightarrow (0, 0) & \text{strongly in } (L^2(\Omega^a))^3 \times (L^2(\Omega^a))^3, \\ \left(\frac{1}{h_n} \frac{\partial p_n^b}{\partial x_2}, \frac{1}{h_n} \frac{\partial p_n^b}{\partial x_3} \right) \rightarrow (0, 0) & \text{strongly in } (L^2(\Omega^b))^3 \times (L^2(\Omega^b))^3, \end{cases} \quad (2.141)$$

$$\left\{ \begin{array}{l}
\phi_{(p_{n_i}^a, p_{n_i}^b)}^a \rightarrow \int_0^{\int_0^{x_3}} p_3^a(t) dt - \int_0^1 \left(\int_0^{x_3} p_3^a(t) dt \right) dx_3 \quad \text{strongly in } H^1(\Omega^a), \\
\phi_{(p_{n_i}^a, p_{n_i}^b)}^b \rightarrow \int_{-\frac{1}{2}}^{\int_0^{x_1}} p_1^b(t) dt - \int_0^1 \left(\int_0^{x_3} p_3^a(t) dt \right) dx_3 - \int_{-\frac{1}{2}}^0 p_1^b(t) dt \quad \text{strongly in } H^1(\Omega^b), \\
\left(\frac{1}{h_n} \frac{\partial \phi_{(p_{n_i}^a, p_{n_i}^b)}^a}{\partial x_1}, \frac{1}{h_n} \frac{\partial \phi_{(p_{n_i}^a, p_{n_i}^b)}^a}{\partial x_2} \right) \rightarrow (0, 0) \quad \text{strongly in } (L^2(\Omega^a))^2, \\
\left(\frac{1}{h_n} \frac{\partial \phi_{(p_{n_i}^a, p_{n_i}^b)}^b}{\partial x_2}, \frac{1}{h_n} \frac{\partial \phi_{(p_{n_i}^a, p_{n_i}^b)}^b}{\partial x_3} \right) \rightarrow (0, 0) \quad \text{strongly in } (L^2(\Omega^b))^2,
\end{array} \right. \quad (2.142)$$

where (p_3^a, p_1^b) solves (2.106). Moreover

$$\lim_n \frac{S_n((p_n^a, p_n^b))}{h_n^2} = E(((0, 0, p_3^a), (p_1^b, 0, 0))). \quad (2.143)$$

2.8.2 A priori estimates on polarization

At first note that (for instance see [29] and also Lemma 2.1 in [47])

$$\|\mathbf{DP}\|_{(L^2(\Omega_n))^9}^2 = \|\mathbf{rot P}\|_{(L^2(\Omega_n))^3}^2 + \|\mathbf{div P}\|_{L^2(\Omega_n)}^2, \forall \mathbf{P} \in (H^1(\Omega_n))^3 : \mathbf{P} \cdot \nu = 0 \text{ on } \partial\Omega_n, \quad (2.144)$$

which by rescalings in (3.8) is transformed into

$$\begin{aligned}
& \|D_n^a p^a\|_{(L^2(\Omega^a))^9}^2 + \|D_n^b p^b\|_{(L^2(\Omega^b))^9}^2 \\
& = \|\mathbf{rot}_n^a p^a\|_{(L^2(\Omega^a))^3}^2 + \|\mathbf{div}_n^a p^a\|_{L^2(\Omega^a)}^2 + \|\mathbf{rot}_n^b p^b\|_{(L^2(\Omega^b))^3}^2 + \|\mathbf{div}_n^b p^b\|_{L^2(\Omega^b)}^2,
\end{aligned} \quad (2.145)$$

for all $(p^a, p^b) \in \tilde{\mathcal{P}}_n$ and all $n \in \mathbb{N}$.

We note that to our aim it is enough to have just an equivalence between the term $\|\mathbf{DP}\|_{(L^2(\Omega_n))^9}^2$ and the term $\|\mathbf{rot P}\|_{(L^2(\Omega_n))^3}^2 + \|\mathbf{div P}\|_{L^2(\Omega_n)}^2$ with a constant independent of n .

PROPOSITION 2.8.1. *Assume (2.30). For every $n \in \mathbb{N}$, let (p_n^a, p_n^b) be a solution to (2.28). Then, there exists a constant c such that*

$$\|p_n^a\|_{(L^4(\Omega^a))^3} \leq c, \quad \|p_n^b\|_{(L^4(\Omega^b))^3} \leq c, \quad \forall n \in \mathbb{N}, \quad (2.146)$$

$$\|D_n^a p_n^a\|_{(L^2(\Omega^a))^9} \leq c, \quad \|D_n^b p_n^b\|_{(L^2(\Omega^b))^9} \leq c, \quad \forall n \in \mathbb{N}. \quad (2.147)$$

Proof. Function 0 belonging to \tilde{P}_n gives

$$\begin{aligned} & \int_{\Omega^a} \left(\beta |\operatorname{rot}_n^a p_n^a|^2 + |\operatorname{div}_n^a p_n^a|^2 + \alpha (|p_n^a|^4 - 2|p_n^a|^2) + |D_n^a \phi_{(p_n^a, p_n^b)}^a|^2 \right) dx \\ & + \int_{\Omega^b} \left(\beta |\operatorname{rot}_n^b p_n^b|^2 + |\operatorname{div}_n^b p_n^b|^2 + \alpha (|p_n^b|^4 - 2|p_n^b|^2) + |D_n^b \phi_{(p_n^a, p_n^b)}^b|^2 \right) dx \\ & \leq \frac{1}{2} \int_{\Omega^a} (|f_n^a|^2 + |p_n^a|^2) dx + \frac{1}{2} \int_{\Omega^b} (|f_n^b|^2 + |p_n^b|^2) dx, \quad \forall n \in \mathbb{N}. \end{aligned} \quad (2.148)$$

Estimates (2.148) implies

$$\begin{aligned} & \int_{\Omega^a} \alpha \left(|p_n^a|^4 - \left(2 + \frac{1}{2\alpha}\right) |p_n^a|^2 \right) dx + \int_{\Omega^b} \alpha \left(|p_n^b|^4 - \left(2 + \frac{1}{2\alpha}\right) |p_n^b|^2 \right) dx \\ & \leq \frac{1}{2} \int_{\Omega^a} |f_n^a|^2 dx + \frac{1}{2} \int_{\Omega^b} |f_n^b|^2 dx, \quad \forall n \in \mathbb{N}, \end{aligned}$$

which gives

$$\begin{aligned} & \int_{\Omega^a} \alpha \left(|p_n^a|^2 - \left(1 + \frac{1}{4\alpha}\right) \right)^2 dx + \int_{\Omega^b} \alpha \left(|p_n^b|^2 - \left(1 + \frac{1}{4\alpha}\right) \right)^2 dx \\ & \leq \alpha \left(1 + \frac{1}{4\alpha}\right)^2 (|\Omega^a| + |\Omega^b|) + \frac{1}{2} \int_{\Omega^a} |f_n^a|^2 dx + \frac{1}{2} \int_{\Omega^b} |f_n^b|^2 dx, \quad \forall n \in \mathbb{N}. \end{aligned} \quad (2.149)$$

Then the estimates in (2.146) follow from (2.149) and (2.30). The estimates in (2.147) follow from (2.148), (2.30), (2.146), the continuous embedding of L^4 into L^2 , and (2.145). \square

Proposition 2.8.1, by the same arguments as in the proof of Corollary 2.2, yields the following result.

COROLLARY 2.4. *Assume (2.30). For every $n \in \mathbb{N}$, let (p_n^a, p_n^b) be a solution to (2.28). Let \tilde{P} be defined in (2.103). Then there exist a subsequence of \mathbb{N} , still denoted by $\{n\}$, and (in possible dependence on the*

subsequence) $(p_3^a, p_1^b) \in \tilde{P}$ such that

$$\begin{cases} p_n^a \rightharpoonup (0, 0, p_3^a) & \text{weakly in } (H^1(\Omega^a))^3 \text{ and strongly in } (L^4(\Omega^a))^3, \\ p_n^b \rightharpoonup (p_1^b, 0, 0) & \text{weakly in } (H^1(\Omega^b))^3 \text{ and strongly in } (L^4(\Omega^b))^3. \end{cases} \quad (2.150)$$

2.8.3 The proof of Theorem 2.4

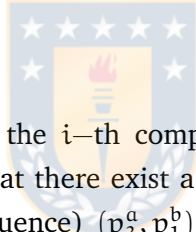

In what follows, $p_{n,i}^a$ (resp. $p_{n,i}^b$) denotes the i -th component, $i = 1, 2, 3$, of p_n^a (resp. p_n^b). Proposition 2.8.1 and Corollary 2.4 assert that there exist a subsequence of \mathbb{N} , still denoted by $\{n\}$, and (in possible dependence on the subsequence) $(p_3^a, p_1^b) \in \tilde{P}$ satisfying (2.150) and $(z^a, z^b) \in (L^2(\Omega^a))^{3 \times 2} \times (L^2(\Omega^b))^{3 \times 2}$ satisfying

$$\begin{cases} \left(\frac{1}{h_n} \frac{\partial p_{n,i}^a}{\partial x_j} \right)_{i=1,2,3,j=1,2} \rightharpoonup z^a \text{ weakly in } (L^2(\Omega^a))^{3 \times 2}, \\ \left(\frac{1}{h_n} \frac{\partial p_{n,i}^b}{\partial x_j} \right)_{i=1,2,3,j=1,2} \rightharpoonup z^b \text{ weakly in } (L^2(\Omega^b))^{3 \times 2}. \end{cases} \quad (2.151)$$

The next step is devoted to identifying p_3^a , p_1^b , z^a , and z^b . To this end, let

$$v = \begin{cases} (0, 0, q_3^a), & \text{in } \Omega^a, \\ (q_1^b, 0, 0), & \text{in } \Omega^b, \end{cases}$$

with $(q_3^a, q_1^b) \in P_{\text{reg}}$ defined in (2.117). Then v belongs to \tilde{P}_n , for n large enough. Consequently,

$$\frac{1}{h_n^2} S_n \left((p_n^a, p_n^b) \right) \leq \frac{1}{h_n^2} S_n \left(((0, 0, q_3^a), (q_1^b, 0, 0)) \right), \text{ for } n \text{ large enough.} \quad (2.152)$$

Then, passing to the limit in (2.152), as n diverges, and using (2.30), (2.150), (2.151), Proposition 2.6.2, and a l.s.c. argument imply

$$\begin{aligned}
& \int_{\Omega^a} \left(\beta \left(|z_{3,2}^a|^2 + |z_{3,1}^a|^2 + |z_{2,1}^a - z_{1,2}^a|^2 \right) + \left(\left| z_{1,1}^a + z_{2,2}^a + \frac{dp_3^a}{dx_3} \right|^2 \right) \right) dx \\
& + \int_0^1 \left(\alpha (|p_3^a|^2 - 1)^2 + |p_3^a|^2 \right) dx_3 + \int_0^1 \left(\int_{]-\frac{1}{2}, \frac{1}{2}[^2} f_3^a dx_1 dx_2 p_3^a \right) dx_3 \\
& + \int_{\Omega^b} \left(\beta \left(|z_{3,2}^b - z_{2,3}^b|^2 + |z_{1,3}^b|^2 + |z_{1,2}^b|^2 \right) + \left(\left| \frac{dp_1^b}{dx_1} + z_{2,2}^b + z_{3,3}^b \right|^2 \right) \right) dx \\
& + \int_{-\frac{1}{2}}^{\frac{1}{2}} \left(\alpha (|p_1^b|^2 - 1)^2 + |p_1^b|^2 \right) dx_1 + \int_{-\frac{1}{2}}^{\frac{1}{2}} \left(\int_{]-\frac{1}{2}, \frac{1}{2}[\times [-1, 0]} f_1^b dx_2 dx_3 p_1^b \right) dx_1 \\
& \leq \liminf_n \frac{S_n((p_n^a, p_n^b))}{h_n^2} \leq \overline{\lim}_n \frac{S_n((p_n^a, p_n^b))}{h_n^2} \\
& \leq \liminf_n \frac{S_n(((0, 0, q_3^a), (q_1^b, 0, 0)))}{h_n^2} = E(((0, 0, q_3^a), (q_1^b, 0, 0))).
\end{aligned} \tag{2.153}$$

Now let us prove that

$$\int_{\Omega^a} (z_{1,1}^a + z_{2,2}^a) \frac{dp_3^a}{dx_3} dx = 0, \quad \int_{\Omega^b} (z_{2,2}^b + z_{3,3}^b) \frac{dp_1^b}{dx_1} dx = 0. \tag{2.154}$$

Indeed, let

$$g_n(x_3) = \sum_{i=0}^{n-1} \left(\frac{p_3^a\left(\frac{i+1}{n}\right) - p_3^a\left(\frac{i}{n}\right)}{\frac{1}{n}} \chi_{\left] \frac{i}{n}, \frac{i+1}{n} \right[}(x_3) \right), \quad x_3 \text{ a.e. in }]0, 1[, \quad \forall n \in \mathbb{N}.$$

Observing that $\frac{p_3^a\left(\frac{i+1}{n}\right) - p_3^a\left(\frac{i}{n}\right)}{\frac{1}{n}}$ is the average of $\frac{dp_3^a}{dx_3}$ on $\left] \frac{i}{n}, \frac{i+1}{n} \right[$, one easily has

$$g_n \rightarrow \frac{dp_3^a}{dx_3} \text{ strongly in } L^2(]0, 1[),$$

as n diverges. Consequently, taking also into account (2.151), one has

$$\begin{aligned} \int_{\Omega^a} (z_{1,1}^a + z_{2,2}^a) \frac{dp_3^a}{dx_3} dx &= \lim_n \int_{\Omega^a} \left(\frac{1}{h_n} \frac{\partial p_{n,1}^a}{\partial x_1}(x) - \frac{1}{h_n} \frac{\partial p_{n,2}^a}{\partial x_2}(x) \right) g_n(x_3) dx \\ &= \lim_n \sum_{i=0}^{n-1} \left(\frac{p_3^a\left(\frac{i+1}{n}\right) - p_3^a\left(\frac{i}{n}\right)}{\frac{1}{n}} \frac{1}{h_n} \int_{]-\frac{1}{2}, \frac{1}{2}[^2 \times \frac{i}{n}, \frac{i+1}{n}[} \left(\frac{\partial p_{n,1}^a}{\partial x_1}(x) - \frac{\partial p_{n,2}^a}{\partial x_2}(x) \right) dx \right) \end{aligned}$$

and the last integrals are zero due to the boundary condition on p_n^a . It is so proved the first equality in (2.154). Similarly, one proves the second one.

The properties of p_3^a , p_1^b and (2.154) give

$$\begin{cases} \int_{\Omega^a} \left| z_{1,1}^a + z_{2,2}^a + \frac{dp_3^a}{dx_3} \right|^2 dx = \int_0^1 \left| \frac{dp_3^a}{dx_3} \right|^2 dx_3 + \int_{\Omega^a} |z_{1,1}^a + z_{2,2}^a|^2 dx, \\ \int_{\Omega^b} \left| \frac{dp_1^b}{dx_1} + z_{2,2}^b + z_{3,3}^b \right|^2 dx = \int_{-\frac{1}{2}}^{\frac{1}{2}} \left| \frac{dp_1^b}{dx_1} \right|^2 dx_1 + \int_{\Omega^b} |z_{2,2}^b + z_{3,3}^b|^2 dx. \end{cases} \quad (2.155)$$

Then, inserting (2.155) in (2.153) provides

$$\begin{aligned} &\int_{\Omega^a} \left[\beta \left(|z_{3,2}^a|^2 + |z_{3,1}^a|^2 + |z_{2,1}^a - z_{1,2}^a|^2 \right) + |z_{1,1}^a + z_{2,2}^a|^2 \right] dx \\ &+ \int_{\Omega^b} \left[\beta \left(|z_{3,2}^b - z_{2,3}^b|^2 + |z_{1,3}^b|^2 + |z_{1,2}^b|^2 \right) + |z_{2,2}^b + z_{3,3}^b|^2 \right] dx \\ &+ E(((0, 0, p_3^a), (p_1^b, 0, 0))) \leq \lim_n \frac{S_n((p_n^a, p_n^b))}{h_n^2} \leq \overline{\lim}_n \frac{S_n((p_n^a, p_n^b))}{h_n^2} \\ &\leq E(((0, 0, q_3^a), (q_1^b, 0, 0))), \quad \forall (q_3^a, q_1^b) \in P_{\text{reg}}. \end{aligned} \quad (2.156)$$

By virtue of Proposition 2.6.3, inequality (2.156) also true for any $(q_3^a, q_1^b) \in \tilde{P}$. Consequently, choos-

ing $(q_3^a, q_1^b) = (p_3^a, p_1^b)$ in (2.156) one has

$$\begin{cases} z_{2,1}^a - z_{1,2}^a = 0 \text{ a.e. in } \Omega^a, z_{1,1}^a + z_{2,2}^a = 0 \text{ a.e. in } \Omega^a, \\ z_{3,2}^a = z_{3,1}^a = 0 \text{ a.e. in } \Omega^a, \\ z_{1,3}^b = z_{1,2}^b = 0 \text{ a.e. in } \Omega^b, z_{3,2}^b - z_{2,3}^b = 0 \text{ a.e. in } \Omega^b, \\ z_{2,2}^b + z_{3,3}^b = 0 \text{ a.e. in } \Omega^b. \end{cases} \quad (2.157)$$

Consequently, inserting (2.157) in (2.156), one obtains that (p_3^a, p_1^b) solves (2.106) and convergence (2.143) holds. We remark that convergence in (2.143) holds true for the whole sequence since the limit is uniquely identified. Moreover, (2.142) follows from (2.150) and Proposition 2.6.2.

The last step is devoted to proving (2.141) and that convergences in (2.150) are strong. To this aim, combining (2.143) with (2.30), (2.142) and (2.150) provides

$$\begin{aligned} & \lim_n \left(\int_{\Omega^a} \left(\beta |\operatorname{rot}_n^a p_n^a|^2 + |\operatorname{div}_n^a p_n^a|^2 \right) dx + \int_{\Omega^b} \left(\beta |\operatorname{rot}_n^b p_n^b|^2 + |\operatorname{div}_n^b p_n^b|^2 \right) dx \right) \\ &= \int_0^1 \left| \frac{dp_3^a}{dx_3} \right|^2 dx_3 + \int_{-\frac{1}{2}}^{\frac{1}{2}} \left| \frac{dp_1^b}{dx_1} \right|^2 dx_1. \end{aligned} \quad (2.158)$$

Moreover, from (2.150), (2.151) and (2.157) it follows that

$$\begin{cases} \operatorname{rot}_n^a p_n^a \rightharpoonup (0, 0, 0) = \operatorname{rot}(0, 0, p_3^a) \quad \text{weakly in } (L^2(\Omega^a))^3, \\ \operatorname{rot}_n^b p_n^b \rightharpoonup (0, 0, 0) = \operatorname{rot}(p_1^b, 0, 0) \quad \text{weakly in } (L^2(\Omega^b))^3, \\ \operatorname{div}_n^a p_n^a \rightharpoonup \frac{dp_3^a}{dx_3} = \operatorname{div}(0, 0, p_3^a) \quad \text{weakly in } L^2(\Omega^a), \\ \operatorname{div}_n^b p_n^b \rightharpoonup \frac{dp_1^b}{dx_1} = \operatorname{div}(p_1^b, 0, 0) \quad \text{weakly in } L^2(\Omega^b). \end{cases} \quad (2.159)$$

Consequently, combining convergence of the energies (2.158) with (2.159), one derives that

$$\begin{cases} \operatorname{rot}_n^a p_n^a \rightarrow \operatorname{rot}(0, 0, p_3^a) \quad \text{strongly in } (L^2(\Omega^a))^3, \\ \operatorname{rot}_n^b p_n^b \rightarrow \operatorname{rot}(p_1^b, 0, 0) \quad \text{strongly in } (L^2(\Omega^b))^3, \\ \operatorname{div}_n^a p_n^a \rightarrow \operatorname{div}(0, 0, p_3^a) \quad \text{strongly in } L^2(\Omega^a), \\ \operatorname{div}_n^b p_n^b \rightarrow \operatorname{div}(p_1^b, 0, 0) \quad \text{strongly in } L^2(\Omega^b). \end{cases} \quad (2.160)$$

Finally, taking into account that

$$\begin{cases} D(0, 0, p_3^a) = D_n^a(0, 0, p_3^a), \operatorname{rot}(0, 0, p_3^a) = \operatorname{rot}_n^a(0, 0, p_3^a), \operatorname{div}(0, 0, p_3^a) = \operatorname{div}_n^a(0, 0, p_3^a), & \text{in } \Omega^a, \\ D(p_1^b, 0, 0) = D_n^b(p_1^b, 0, 0), \operatorname{rot}(p_1^b, 0, 0) = \operatorname{rot}_n^b(p_1^b, 0, 0), \operatorname{div}(p_1^b, 0, 0) = \operatorname{div}_n^b(p_1^b, 0, 0), & \text{in } \Omega^b, \end{cases}$$

from (2.145) and (2.160) one deduces that

$$\begin{cases} D_n^a p_n^a \rightarrow D(0, 0, p_3^a) & \text{strongly in } (L^2(\Omega^a))^9, \\ D_n^b p_n^b \rightarrow D(p_1^b, 0, 0) & \text{strongly in } (L^2(\Omega^b))^9, \end{cases}$$

i.e. (2.141) and that convergences in (2.150) are strong. We remark that convergences in (2.141) hold true for the whole sequence since the limits are uniquely identified. \square

2.9 The asymptotic behavior of all previous problems when the control φ_P satisfies (2.8)

If $(\phi_{(p^a, p^b)}^a, \phi_{(p^a, p^b)}^b)$ is the unique solution to (2.29), thanks to Proposition 2.4.3, in the limit process there is no contribution of the nonlocal term. So, the limit functionals are obtained just eliminating the parts coming from the nonlocal term in the previous limit functionals and all previous convergences on the polarization hold true, while the potentials converge to zero.

PART III

Asymptotic Analysis of a Junction of Hyperelastic Rods



Asymptotic Analysis of a Junction of Hyperelastic Rods

P. Hernández-Llanos, Asymptotic Analysis of a Junction of Hyperelastic Rods, *Submitted*.

Abstract. In this chapter, we obtain a 1-dimensional model asymptotic model for a junction of thin hyperelastic rods as the thickness goes to zero. We show, under appropriate hypotheses on the loads, that the deformations which minimize the total energy weakly converge in a Sobolev space towards the minimum of a 1D-dimensional energy for elastic strings by using techniques from Γ -convergence.

Keywords: Junctions, thin structures, hyperelasticity, nonlinear elasticity, thin beams, asymptotic analysis.

2010 AMS subject classifications: 35B40, 74B20, 74K30.

3.1 Introduction

The asymptotic modeling for thin structures (plates, shells, beams, etc) by Γ -convergence from 3D–nonlinear elasticity equations has been of special interest for the mathematical community during the last four decades (see, for instance [7, 14, 23, 25, 26, 28, 37, 38, 39, 40, 53, 54, 59, 60, 61, 62, 64, 65, 66, 73, 74]) motivated by applications in engineering. Going further, complex structures are obtained by a junction of much simpler structures. Examples of such thin multistructures are bridges

(where, for instance, cables are connected to the board of the bridge) and T– or L–shaped junctions of rods.

There exists an extensive literature on dimension reduction problems related to multi-structures in the context of nonlinear hyperelasticity for which we refer to [11, 48, 35, 36, 56, 49, 51, 52, 72]. For literature on multi-structures in contexts other than non-linear hyperelasticity, we refer to Gaudiello et al [41, 43, 44, 45, 46, 47, 48, 49] and, more recently, [16, 18] for a large number of interesting problems involving ferroelectricity, electromagnetism, diffusion, etc.

In this chapter, starting from the 3D–model of a junction of two orthogonal non-linearly hyperelastic thin rods joined to each other (see Figure 3.1), we obtain a 1D–model. The aim is to extend the results of Acerbi et al [1] for the case of an elastic string to a multiple structure. For obtaining the limit model we shall closely follow the arguments provided by Le Dret and Raoult [58] in obtaining a 2-d model for a membrane starting from the 3-d model for a hyperelastic structure. The approach is classical and consists of rescaling the problem and studying the Γ -limit of rescaled energies by establishing the Γ – \liminf inequality and the Γ – $\overline{\lim}$ inequality. The main novelty compared to the elastic string model of Acerbi et al[1] is the appearance of the junction condition, although it is natural to expect this in the case of multi-structures. The junction condition appears when the elastic energy has a certain growth rate. The justification of the junction condition, during the proof of the Γ – \liminf inequality, is not so immediate but can be obtained following the ideas of Gaudiello et al[41]. The junction condition is taken care of during the derivation of the Γ – $\overline{\lim}$ inequality using a recovery sequence which is constructed inspired by the construction used in Le Dret et al[58] and in Gaudiello et al[41]

The chapter is organized as follows. Section 3.2 begins with the basic background about our multidomain in the context of 3D elasticity. Then it is followed by a rescaling of the problem and we define the appropriate Sobolev spaces for the deformations and displacements involved in the rescaled problem. The main result (Theorem 3.1) of the chapter is given in Section 3.2.4. We begin Section 3.3 with Lemma 3.1 and Propositions 3.3.1, 3.3.2 and Theorem 3.1 is proved with their help. Finally, in Section 3.4, we end by computing the 1-d stored energy in the case of the Saint Venant-Kirchhoff material for the junction (Proposition 3.4.1).

3.2 Preliminaries

3.2.1 Notation and definitions

Throughout this paper, we denote by $\mathbb{N}, \mathbb{R}, \mathbb{R}^+$ and $\mathbb{R}^{m \times n}$ the sets of natural, real, nonnegative real numbers and the space of real $m \times n$ matrices endowed with the usual Euclidean norm $\|F\| = \sqrt{\text{tr } F^T F}$ respectively. For all $z_i \in \mathbb{R}^3$, $i = 1, 2, 3$, we note $(z_1|z_2|z_3)$ the matrix whose i -th column is z_i . In the sequel, $x = (x_1, x_2, x_3)$ denotes a generic point in \mathbb{R}^3 .

For all $\bar{F} = (z_1|z_2) \in \mathbb{R}^{3 \times 2}$ and $z_3 \in \mathbb{R}^3$, we also note $(\bar{F}|z_3)$ the matrix whose first two columns are z_1 and z_2 and whose third column is z_3 . Analogously, for all $\tilde{F} = (z_2|z_3) \in \mathbb{R}^{3 \times 2}$ and $z_1 \in \mathbb{R}^3$, we also note $(z_1|\tilde{F})$ the matrix whose first column is z_1 and the last two columns are z_2 and z_3 .

We assume that $W : \mathbb{R}^{3 \times 3} \rightarrow \mathbb{R}$ is a continuous function that satisfies the following growth and coercivity hypotheses:

$$\begin{cases} \exists C > 0, \exists p \in]1, +\infty[, \forall F \in \mathbb{R}^{3 \times 3}, & |W(F)| \leq C(1 + \|F\|^p), \\ \exists \alpha > 0, \exists \beta \geq 0, \forall F \in \mathbb{R}^{3 \times 3}, & W(F) \geq \alpha\|F\|^p - \beta. \end{cases} \quad (3.1)$$

Given such $W : \mathbb{R}^{3 \times 3} \rightarrow \mathbb{R}$, we introduce two functions $W_a, W_b : \mathbb{R}^3 \rightarrow \mathbb{R}$

$$W_a(z_3) = \inf_{\bar{F} \in \mathbb{R}^{3 \times 2}} W((\bar{F}|z_3)), \quad W_b(z_1) = \inf_{\tilde{F} \in \mathbb{R}^{3 \times 2}} W((z_1|\tilde{F})). \quad (3.2)$$

Due to the coercivity assumption (3.1)₂, it is clear that these functions are well defined. Besides, since W is continuous, the infimum for both are attained. Let us briefly state a few properties of W_a and W_b . The continuity of W_a and W_b on \mathbb{R}^3 is a consequence of (3.1)₂ (see e.g. [1, 58]) and these functions satisfy the growth and coecivity estimates

$$\begin{cases} \exists C' > 0, \forall z \in \mathbb{R}^3 & |W_a(z)| \leq C'(1 + \|z\|^p), \\ \exists \alpha > 0, \exists \beta \geq 0, \forall z \in \mathbb{R}^3, & W_a(z) \geq \alpha\|z\|^p - \beta, \end{cases} \quad (3.3)$$

$$\begin{cases} \exists C' > 0, \forall z \in \mathbb{R}^3 & |W_b(z)| \leq C'(1 + \|z\|^p), \\ \exists \alpha > 0, \exists \beta \geq 0, \forall z \in \mathbb{R}^3, & W_b(z) \geq \alpha\|z\|^p - \beta. \end{cases} \quad (3.4)$$

3.2.2 Setting up of the three-dimensional problem

For all $\varepsilon > 0$, we introduce the thin multidomain $\Omega_\varepsilon := \Omega_\varepsilon^a \cup \Omega_\varepsilon^b$ (see Figure 3.1), where

$$\Omega_\varepsilon^a = \left(\left(-\frac{\varepsilon}{2}, \frac{\varepsilon}{2} \right) \times \left(-\frac{\varepsilon}{2}, \frac{\varepsilon}{2} \right) \right) \times [0, 1), \quad \Omega_\varepsilon^b = \left(-\frac{1}{2}, \frac{1}{2} \right) \times \left(\left(-\frac{\varepsilon}{2}, \frac{\varepsilon}{2} \right) \times (-\varepsilon, 0) \right).$$

The multidomain Ω_ε models a nonlinearly hyperelastic body consisting of two joined orthogonal rods Ω_ε^a and Ω_ε^b with small thickness ε which are joined along the surface $\varepsilon \left(-\frac{1}{2}, \frac{1}{2} \right)^2 \times \{0\}$.

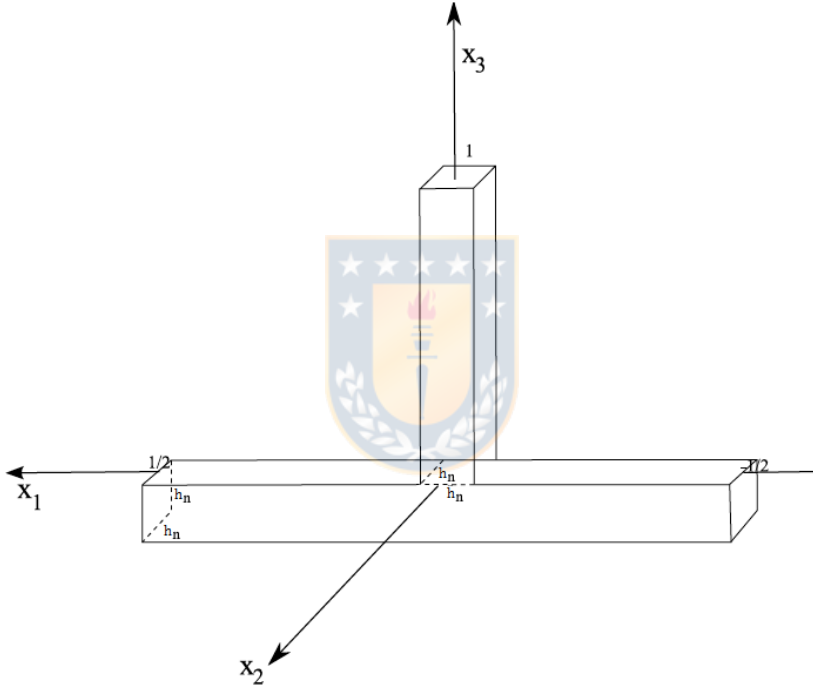

Figure 3.1 The set Ω_ε .

Let

$$\begin{aligned} \Sigma_\varepsilon^a &= \{\pm \frac{\varepsilon}{2}\} \times \left(-\frac{\varepsilon}{2}, \frac{\varepsilon}{2} \right) \times (0, 1) \cup \left(-\frac{\varepsilon}{2}, \frac{\varepsilon}{2} \right) \times \{\pm \frac{\varepsilon}{2}\} \times (0, 1), \\ \Sigma_\varepsilon^b &= \left(-\frac{1}{2}, \frac{1}{2} \right) \times \{\pm \frac{\varepsilon}{2}\} \times (-\varepsilon, 0) \cup \left(-\frac{1}{2}, \frac{1}{2} \right) \times \left(-\frac{\varepsilon}{2}, \frac{\varepsilon}{2} \right) \times \{-1\}, \\ \Gamma_\varepsilon^a &= \left(-\frac{\varepsilon}{2}, \frac{\varepsilon}{2} \right)^2 \times \{1\}, \quad \mathcal{S}_\varepsilon^b = \{\pm \frac{1}{2}\} \times \left(\left(-\frac{\varepsilon}{2}, \frac{\varepsilon}{2} \right) \times (-\varepsilon, 0) \right), \end{aligned}$$

where Γ_ε^a is the top of the vertical rod, $\mathcal{S}_\varepsilon^b$ corresponds to the ends of the horizontal rod; Σ_ε^a corresponds

to the sides of the vertical rod and Σ_ε^b corresponds to the sides of the horizontal rod except the top portion $((-\frac{1}{2}, \frac{1}{2}) \times (-\frac{\varepsilon}{2}, \frac{\varepsilon}{2}) \setminus (-\frac{\varepsilon}{2}, \frac{\varepsilon}{2})^2) \times \{0\}$ (we exclude this solely in order to lighten the notations and the proofs).

We consider Ω_ε to be the reference configuration of a three-dimensional body made of a non-linearly hyperelastic homogeneous material and whose stored energy function is denoted by W . We suppose that the structure is solely submitted to the action of dead loading on $\Sigma_\varepsilon^a \cup \Sigma_\varepsilon^b$ of traction densities g^ε of small order (see (3.10) and (3.15) for the precise assumptions on g^ε) whereas the multidomain does not deform on $T_\varepsilon^a \cup S_\varepsilon^b$. The equilibrium position is obtained through the minimization problem:

$$\inf_{\psi \in \Phi_\varepsilon} I_\varepsilon(\psi), \quad (3.5)$$

for the total energy I_ε

$$I_\varepsilon(\phi) = \int_{\Omega_\varepsilon} W(D\phi(x)) \, dx - \int_{\Sigma_\varepsilon^a \cup \Sigma_\varepsilon^b} g^\varepsilon(x) \cdot \phi(x) \, d\sigma, \quad (3.6)$$

over the set of admissible deformations

$$\Phi_\varepsilon = \{\phi \in W^{1,p}(\Omega_\varepsilon; \mathbb{R}^3); \phi(x) = x \text{ on } T_\varepsilon^a \text{ and on } S_\varepsilon^b\}. \quad (3.7)$$

In the above, $d\sigma$ is the surface element on $\Sigma_\varepsilon^a \cup \Sigma_\varepsilon^b$.

Under assumptions (3.1), the energy functional I_ε is coercive and, is sequentially weakly lower semi-continuous on $W^{1,p}(\Omega_\varepsilon; \mathbb{R}^3)$ if W is quasiconvex by a classical result of calculus of variations (see Dacorogna [31]). The importance of the quasiconvexity of W is that it guarantees the existence of a solution to the problem (3.6). However, we shall not assume the polyconvexity or quasiconvexity of W since we do not want to rule out important classes of elastic materials such as the Saint-Venant-Kirchhoff which are neither polyconvex nor quasiconvex (see [67]). The convergence results will apply to approximate minimizing sequences as in [58].

3.2.3 The rescaled problem

As is usual, the problem (3.5) is reformulated on a reference domain $\Omega^a \cup \Omega^b$ independent of ε where

$$\Omega^a = \left(-\frac{1}{2}, \frac{1}{2}\right) \times \left(-\frac{1}{2}, \frac{1}{2}\right) \times (0, 1), \quad \Omega^b = \left(-\frac{1}{2}, \frac{1}{2}\right) \times \left(-\frac{1}{2}, \frac{1}{2}\right) \times (-1, 0) \quad (3.8)$$

and we denote by

$$\begin{aligned}\Sigma^a &= \{\pm \frac{1}{2}\} \times (-\frac{1}{2}, \frac{1}{2}) \times (0, 1) \cup (-\frac{1}{2}, \frac{1}{2}) \times \{\pm \frac{1}{2}\} \times (0, 1), \\ \Sigma^b &= (-\frac{1}{2}, \frac{1}{2}) \times \{\pm \frac{1}{2}\} \times (-1, 0) \cup (-\frac{1}{2}, \frac{1}{2})^2 \times \{-1\}, \\ \Gamma^a &= (-\frac{1}{2}, \frac{1}{2})^2 \times \{1\}, \quad \Gamma^b = \{\pm \frac{1}{2}\} \times (-\frac{1}{2}, \frac{1}{2}) \times (-1, 0).\end{aligned}$$

The scaling $r_\varepsilon : (y_1, y_2, x_3) \in \Omega^a \mapsto (\varepsilon y_1, \varepsilon y_2, x_3) \in \text{Int } \Omega_\varepsilon^a$ maps Ω^a, Σ^a and Γ^a , respectively, to $\Omega_\varepsilon^a, \Sigma_\varepsilon^a$ and Γ_ε^a and the scaling $s_\varepsilon : (x_1, y_2, y_3) \in \Omega^b \mapsto (x_1, \varepsilon y_2, \varepsilon y_3) \in \Omega_\varepsilon^b$ maps Ω^b, Σ^b , and Γ^b , respectively, to $\Omega_\varepsilon^b, \Sigma_\varepsilon^b$ and Γ_ε^b .

For every $\phi \in W^{1,p}(\Omega_\varepsilon; \mathbb{R}^3)$, we define

$$\begin{cases} \psi^a(\varepsilon)(y_1, y_2, x_3) := \phi(r_\varepsilon(y_1, y_2, x_3)) & (y_1, y_2, x_3) \in \Omega^a, \\ \psi^b(\varepsilon)(x_1, y_2, y_3) := \phi(s_\varepsilon(x_1, y_2, y_3)) & (x_1, y_2, y_3) \in \Omega^b, \end{cases} \quad (3.9)$$

and given a surface density g^ε on $\Sigma_\varepsilon^a \cup \Sigma_\varepsilon^b$, we define a rescaled surface density $g(\varepsilon)$ defined componentwise on Σ^a and Σ^b through

$$\begin{cases} g^a(\varepsilon)(y_1, y_2, x_3) = \varepsilon^{-1} g^\varepsilon(\varepsilon y_1, \varepsilon y_2, x_3), & \text{for } (y_1, y_2, x_3) \in \Sigma^a, \\ g^b(\varepsilon)(x_1, y_2, y_3) = \varepsilon^{-1} g^\varepsilon(x_1, \varepsilon y_2, \varepsilon y_3), & \text{for } (x_1, y_2, y_3) \in \Sigma^b. \end{cases} \quad (3.10)$$

Define the set

$$\begin{aligned}\Psi(\varepsilon) &= \{\psi = (\psi^a, \psi^b) \in W^{1,p}(\Omega^a; \mathbb{R}^3) \times W^{1,p}(\Omega^b; \mathbb{R}^3) : \psi^a = r_\varepsilon \text{ on } \Gamma^a, \psi^b = s_\varepsilon \text{ on } \Gamma^b, \\ &\quad \psi^a(y_1, y_2, 0) = \psi^b(\varepsilon y_1, y_2, 0) \text{ in } (-\frac{1}{2}, \frac{1}{2})^2\}.\end{aligned} \quad (3.11)$$

We observe that, if $\phi \in \Phi_\varepsilon$ then $(\psi^a(\varepsilon), \psi^b(\varepsilon))$ given by (3.9) belongs to $\Psi(\varepsilon)$ and this defines a bijection between Φ_ε and Ψ_ε . Also observe that, through a change of variables, we have

$$\begin{aligned}I_\varepsilon(\phi) &= \varepsilon^2 \left(\int_{\Omega^a} W \left(\frac{1}{\varepsilon} \frac{\partial \psi^a(\varepsilon)}{\partial y_1} \Big| \frac{1}{\varepsilon} \frac{\partial \psi^a(\varepsilon)}{\partial y_2} \Big| \frac{\partial \psi^a(\varepsilon)}{\partial x_3} \right) dx + \int_{\Omega^b} W \left(\frac{\partial \psi^b(\varepsilon)}{\partial x_1} \Big| \frac{1}{\varepsilon} \frac{\partial \psi^b(\varepsilon)}{\partial y_2} \Big| \frac{1}{\varepsilon} \frac{\partial \psi^b(\varepsilon)}{\partial y_3} \right) dx \right. \\ &\quad \left. - \int_{\Sigma^a} g^a(\varepsilon) \psi^a(\varepsilon) d\zeta - \int_{\Sigma^b} g^b(\varepsilon) \psi^b(\varepsilon) d\zeta \right).\end{aligned} \quad (3.12)$$

In view of the above calculation, we define the rescaled functional

$$\begin{aligned} I(\varepsilon)(\psi) := & \int_{\Omega^a} W \left(\frac{1}{\varepsilon} \frac{\partial \psi^a}{\partial x_1} \middle| \frac{1}{\varepsilon} \frac{\partial \psi^a}{\partial x_2} \middle| \frac{\partial \psi^a}{\partial x_3} \right) dx + \int_{\Omega^b} W \left(\frac{\partial \psi^b}{\partial x_1} \middle| \frac{1}{\varepsilon} \frac{\partial \psi^b}{\partial x_2} \middle| \frac{1}{\varepsilon} \frac{\partial \psi^b}{\partial x_3} \right) dx \\ & - \int_{\Sigma^a} g^a(\varepsilon) \psi^a d\zeta - \int_{\Sigma^b} g^b(\varepsilon) \psi^b d\zeta. \end{aligned} \quad (3.13)$$

By these considerations, we are able to establish a correspondence between the minimization problem (3.5) and the following minimization problem

$$\inf_{\psi \in \Psi(\varepsilon)} I(\varepsilon)(\psi). \quad (3.14)$$

The goal of this paper is to study the asymptotic behaviour, as $\varepsilon \rightarrow 0$, of problem (3.14), under the following assumptions

$$g^a(\varepsilon) \rightharpoonup g^a \quad \text{weakly in } L^q \left(\Sigma^a; \mathbb{R}^3 \right), \quad g^b(\varepsilon) \rightharpoonup g^b \quad \text{weakly in } L^q \left(\Sigma^b; \mathbb{R}^3 \right). \quad (3.15)$$

As in [58], we can rewrite the problem (3.14) in terms of displacements on the rescaled domain. For this end, we define appropriate spaces. Let

$$\mathcal{Z}^p = W_a^{1,p}(\Omega^a; \mathbb{R}^3) \times W_b^{1,p}(\Omega^b; \mathbb{R}^3), \quad (3.16)$$

where $W_a^{1,p}(\Omega^a; \mathbb{R}^3) = \{u^a \in W^{1,p}(\Omega^a; \mathbb{R}^3) : u^a = 0 \text{ on } \Gamma^a\}$ and similarly, $W_b^{1,p}(\Omega^b; \mathbb{R}^3) = \{u^b \in W^{1,p}(\Omega^b; \mathbb{R}^3) : u^b = 0 \text{ on } S^b\}$. There is a natural bijection between the deformations in $\Psi(\varepsilon)$ and the displacements in

$$V(\varepsilon) = \left\{ v = (v^a, v^b) \in \mathcal{Z}^p : v^a(x_1, x_2, 0) = v^b(\varepsilon x_1, x_2, 0) \text{ in } \left(-\frac{1}{2}, \frac{1}{2}\right)^2 \right\}, \quad (3.17)$$

given by

$$v^a = \psi^a - r_\varepsilon \text{ on } \Omega^a, \quad v^b = \psi^b - s_\varepsilon \text{ on } \Omega^b. \quad (3.18)$$

Therefore, in terms of displacements, the rescaled energy (3.13) may be written as:

$$\begin{aligned} J(\varepsilon)(v^a, v^b) = & \int_{\Omega^a} W \left(\left(e_1 + \frac{1}{\varepsilon} \frac{\partial v^a}{\partial x_1} \middle| e_2 + \frac{1}{\varepsilon} \frac{\partial v^a}{\partial x_2} \middle| e_3 + \frac{\partial v^a}{\partial x_3} \right) \right) dx \\ & + \int_{\Omega^b} W \left(\left(e_1 + \frac{\partial v^b}{\partial x_1} \middle| e_2 + \frac{1}{\varepsilon} \frac{\partial v^b}{\partial x_2} \middle| e_3 + \frac{1}{\varepsilon} \frac{\partial v^b}{\partial x_3} \right) \right) dx \\ & - \int_{\Sigma^a} g^a(\varepsilon) \cdot ((0, 0, x_3) + v^a) d\zeta - \int_{\Sigma^b} g^b(\varepsilon) \cdot ((x_1, 0, 0) + v^b) d\zeta \end{aligned} \quad (3.19)$$

for $(v^a, v^b) \in V(\varepsilon)$. Thus the minimization problem (3.14) is equivalent to the following minimization problem

$$\inf_{v=(v^a, v^b) \in V(\varepsilon)} J(\varepsilon)(v). \quad (3.20)$$

3.2.4 The main result

Let us consider the extension of the energies $J(\varepsilon)$ defined by

$$\tilde{J}(\varepsilon)(v) = \begin{cases} J(\varepsilon)(v) & \text{if } v \in V(\varepsilon), \\ +\infty & \text{otherwise,} \end{cases} \quad (3.21)$$

for $v \in L^p(\Omega^a; \mathbb{R}^3) \times L^p(\Omega^b; \mathbb{R}^3)$. The asymptotic behaviour of the energies (3.14) or, equivalently, (3.20) will be obtained through the Γ -limit of the sequence $\tilde{J}(\varepsilon)$ for the strong topology on $L^p(\Omega^a; \mathbb{R}^3) \times L^p(\Omega^b; \mathbb{R}^3)$ when $\varepsilon \rightarrow 0$. We refer to Dal Maso [32] and Braides [12] for the definition and main properties of Γ -convergence.

We introduce the following functional space:

$$V_J = \{(v^a, v^b) \in \mathcal{Z}^p : v^a \text{ is independent of } (x_1, x_2), v^b \text{ is independent of } (x_2, x_3), \text{ and for } p > 2, v^a(0) = v^b(0)\}$$

V_J is called the space of displacements on the T-shaped structure, the subscript J stands for the junction condition. The space V_J is canonically isomorphic to

$$\bar{V}_J = \{(\bar{v}^a, \bar{v}^b) \in W_a^{1,p}((0, 1); \mathbb{R}^3) \times W_b^{1,p}((-\frac{1}{2}, \frac{1}{2}); \mathbb{R}^3) : \text{for } p > 2, \bar{v}^a(0) = \bar{v}^b(0)\}, \quad (3.22)$$

where $W_a^{1,p}((0, 1); \mathbb{R}^3) = \{\bar{w} \in W^{1,p}((0, 1); \mathbb{R}^3) : \bar{w}(1) = 0\}$ and $W_b^{1,p}((-\frac{1}{2}, \frac{1}{2}); \mathbb{R}^3) = W_0^{1,p}((-\frac{1}{2}, \frac{1}{2}); \mathbb{R}^3)$. The functions of a single variable $(\bar{v}^a, \bar{v}^b) \in \bar{V}_J$ are continuous and we denote by $\bar{v} = (\bar{v}^a, \bar{v}^b)$ the element of \bar{V}_J that is associated with $v = (v^a, v^b) \in V_J$ through this isomorphism.

Let W_a and W_b be as defined in (3.2) and, W_a^{**} and W_b^{**} , their respective convex envelopes on \mathbb{R}^3 . Consider the functional

$$\begin{aligned} J(0)(v^a, v^b) &= \int_0^1 W_a^{**} \left(e_3 + \frac{d\bar{v}^a}{dx_3} \right) dx_3 + \int_{-1/2}^{1/2} W_b^{**} \left(e_1 + \frac{d\bar{v}^b}{dx_1} \right) dx_1 \\ &\quad - \int_0^1 \bar{g}^a \cdot ((0, 0, x_3) + \bar{v}^a) dx_3 - \int_{-1/2}^{1/2} \bar{g}^b \cdot ((x_1, 0, 0) + \bar{v}^b) dx_1 \end{aligned} \quad (3.23)$$

for $(v^a, v^b) \in V_J$, where \bar{g}^a, \bar{g}^b are defined below:

$$\bar{g}^a(x_3) := \sum_{i=1}^2 \int_{-1/2}^{1/2} g^a(y_1, (-1)^i \frac{1}{2}, x_3) dy_1 + \sum_{i=1}^2 \int_{-1/2}^{1/2} g^a((-1)^i \frac{1}{2}, y_2, x_3) dy_2 \quad (3.24)$$

$$\bar{g}^b(x_1) := \sum_{i=1}^2 \int_{-1}^0 g^b(x_1, (-1)^i \frac{1}{2}, y_3) dy_3 + \int_{-1/2}^{1/2} g^b(x_1, y_2, -1) dy_2 \quad (3.25)$$

We then extend $J(0)$ to $L^p(\Omega^a; \mathbb{R}^3) \times L^p(\Omega^b; \mathbb{R}^3)$ as follows

$$\tilde{J}(0)(v) = \begin{cases} J(0)(v), & \text{if } v \in V_J, \\ +\infty, & \text{otherwise.} \end{cases} \quad (3.26)$$

The following theorem is our main result.

THEOREM 3.1. *Assume (3.15), and that there exist $C > 0$, $\alpha > 0$, $\beta \geq 0$, and some $p > 2$ such that the stored energy function $W : \mathbb{R}^{3 \times 3} \rightarrow \mathbb{R}$ of the hyperelastic material satisfies the growth and coercivity conditions (3.1)-(3.4). Then, the sequence of energies $\tilde{J}(\varepsilon)$ given in (3.21) and (3.19) Γ -converges, as $\varepsilon \rightarrow 0$, to $\tilde{J}(0)$ for the strong topology of $L^p(\Omega^a; \mathbb{R}^3) \times L^p(\Omega^b; \mathbb{R}^3)$. \square*

As a corollary of the Γ -convergence and of the equicoercivity of the functionals $\tilde{J}(\varepsilon)$ it follows, by classical results in Γ -convergence theory, that the minima converge and also any sequence of approximate minimizers converge to a minimum of the limit problem. This means that the deformations of the original structure in equilibrium or near an equilibrium may be approximated by the deformations in equilibrium of the limiting energy.

Remark: We do not consider the case $p \leq 2$ since it can be shown that, for this case, there is no condition on the junction in the limit problem and so the vertical and horizontal segments act independently and so there is no difference from the model obtained by Acerbi et al[1].

3.3 Proof of the main theorem

For clarity, we decompose the proof of Theorem 3.1 into a series of various comparatively simple results. The assumptions on W are as in the theorem for the following lemma.

LEMMA 3.1. *Let $u(\varepsilon) = (u^a(\varepsilon), u^b(\varepsilon)) \in L^p(\Omega^a; \mathbb{R}^3) \times L^p(\Omega^b; \mathbb{R}^3)$ be a sequence such that $\tilde{J}(\varepsilon)(u(\varepsilon)) \leq$*

$C < +\infty$ where C does not depend on ε . Then $u(\varepsilon)$ is uniformly bounded in \mathcal{Z}^p and any limit point for the weak topology of \mathcal{Z}^p belongs to V_J .

Proof. Let $u(\varepsilon) = (u^a(\varepsilon), u^b(\varepsilon)) \in L^p(\Omega^a; \mathbb{R}^3) \times L^p(\Omega^b; \mathbb{R}^3)$ be such that $\tilde{J}(\varepsilon)(u(\varepsilon)) \leq C < +\infty$. Then, the definition (3.21) implies that $u(\varepsilon) = (u^a(\varepsilon), u^b(\varepsilon)) \in V(\varepsilon)$ for all $\varepsilon > 0$. Let us call $\psi^a(\varepsilon) = u^a(\varepsilon) + r_\varepsilon$ and $\psi^b(\varepsilon) = u^b(\varepsilon) + s_\varepsilon$, the deformations that are associated with the displacements $u^a(\varepsilon)$ and $u^b(\varepsilon)$, respectively, where r_ε and s_ε are as defined in subsection 3.2.3. The coercivity of the function W and the assumed uniform bound for the energies imply that

$$\alpha \int_{\Omega^a} \left| \left(\frac{1}{\varepsilon} \partial_1 \psi^a(\varepsilon) \middle| \frac{1}{\varepsilon} \partial_2 \psi^a(\varepsilon) \middle| \partial_3 \psi^a(\varepsilon) \right) \right|^p dx \leq C' \left(1 + \|\psi^a(\varepsilon)\|_{W^{1,p}(\Omega^a; \mathbb{R}^3)} \right), \quad (3.27)$$

$$\alpha \int_{\Omega^b} \left| \left(\partial_1 \psi^b(\varepsilon) \middle| \frac{1}{\varepsilon} \partial_2 \psi^b(\varepsilon) \middle| \frac{1}{\varepsilon} \partial_3 \psi^b(\varepsilon) \right) \right|^p dx \leq C' \left(1 + \|\psi^b(\varepsilon)\|_{W^{1,p}(\Omega^b; \mathbb{R}^3)} \right), \quad (3.28)$$

where C' does not depend on ε . It is clear that for $\varepsilon > 0$ such that $\varepsilon \leq 1$, we have

$$\left\| \left(\varepsilon^{-1} z_1 \middle| \varepsilon^{-1} z_2 \middle| z_3 \right) \right\| \geq \|(z_1 | z_2 | z_3)\|, \quad \left\| \left(z_1 \middle| \varepsilon^{-1} z_2 \middle| \varepsilon^{-1} z_3 \right) \right\| \geq \|(z_1 | z_2 | z_3)\|.$$

Therefore (3.27) and (3.28) imply that

$$\alpha \|D\psi^a(\varepsilon)\|_{L^p(\Omega^a; \mathbb{R}^3)}^p \leq C' \left(1 + \|\psi^a(\varepsilon)\|_{W^{1,p}(\Omega^a; \mathbb{R}^3)} \right), \quad (3.29)$$

$$\alpha \|D\psi^b(\varepsilon)\|_{L^p(\Omega^b; \mathbb{R}^3)}^p \leq C' \left(1 + \|\psi^b(\varepsilon)\|_{W^{1,p}(\Omega^b; \mathbb{R}^3)} \right), \quad (3.30)$$

which, together with the clamped conditions

$$\psi^a(\varepsilon) = r_\varepsilon \text{ on } T^a \text{ and } \psi^b(\varepsilon) = s_\varepsilon \text{ on } S^b \quad (3.31)$$

yield the desired uniform bound for $\psi^a(\varepsilon)$ and $\psi^b(\varepsilon)$ in $W^{1,p}(\Omega^a; \mathbb{R}^3)$ and $W^{1,p}(\Omega^b; \mathbb{R}^3)$, respectively, by Poincaré inequality.

Then, going back to (3.27), (3.28) and using a priori bounds on $\psi^a(\varepsilon)$ and $\psi^b(\varepsilon)$, we obtain

$$\|\partial_1 \psi^a(\varepsilon)\|_{L^p(\Omega^a; \mathbb{R}^3)} \leq C''' \varepsilon, \quad \|\partial_2 \psi^a(\varepsilon)\|_{L^p(\Omega^a; \mathbb{R}^3)} \leq C''' \varepsilon \quad \text{and}, \quad (3.32)$$

$$\|\partial_2 \psi^b(\varepsilon)\|_{L^p(\Omega^b; \mathbb{R}^3)} \leq C''' \varepsilon, \quad \|\partial_3 \psi^b(\varepsilon)\|_{L^p(\Omega^b; \mathbb{R}^3)} \leq C''' \varepsilon. \quad (3.33)$$

Therefore,

$$\begin{aligned} \partial_1 \psi^\alpha(\varepsilon) &\rightarrow 0 \quad \text{strongly in } L^p(\Omega^\alpha; \mathbb{R}^3), & \partial_2 \psi^\alpha(\varepsilon) &\rightarrow 0 \quad \text{strongly in } L^p(\Omega^\alpha; \mathbb{R}^3) \quad \text{and,} \\ \partial_2 \psi^b(\varepsilon) &\rightarrow 0 \quad \text{strongly in } L^p(\Omega^b; \mathbb{R}^3), & \partial_3 \psi^b(\varepsilon) &\rightarrow 0 \quad \text{strongly in } L^p(\Omega^b; \mathbb{R}^3). \end{aligned} \quad (3.34)$$

If we denote ψ^α and ψ^b as limit points of the sequences $\psi^\alpha(\varepsilon)$ and $\psi^b(\varepsilon)$ in the weak topology of the corresponding spaces $W^{1,p}(\Omega^\alpha; \mathbb{R}^3)$ and $W^{1,p}(\Omega^b; \mathbb{R}^3)$, (for the strong topology of $L^p(\Omega^\alpha; \mathbb{R}^3)$ and $L^p(\Omega^b; \mathbb{R}^3)$ respectively), i.e.

$$\begin{aligned} \psi^\alpha(\varepsilon) &\rightharpoonup \psi^\alpha \quad \text{weakly in } W^{1,p}(\Omega^\alpha; \mathbb{R}^2) \quad \text{and strongly in } L^p(\Omega^\alpha; \mathbb{R}^3), \\ \psi^b(\varepsilon) &\rightharpoonup \psi^b \quad \text{weakly in } W^{1,p}(\Omega^b; \mathbb{R}^2) \quad \text{and strongly in } L^p(\Omega^b; \mathbb{R}^3), \end{aligned} \quad (3.35)$$

it follows at once that

$$\partial_1 \psi^\alpha = 0, \quad \partial_2 \psi^\alpha = 0, \quad \partial_2 \psi^b = 0, \quad \partial_3 \psi^b = 0. \quad (3.36)$$

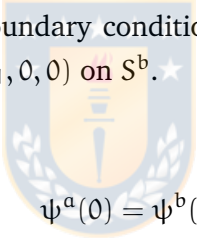
Thus, ψ^α is independent of (x_1, x_2) and ψ^b is independent of (x_2, x_3) . On the other hand, from (3.36) and again by virtue of the clamped boundary conditions (3.31) for $\psi = (\psi^\alpha, \psi^b)$ we deduce that $\psi^\alpha(x) = (0, 0, x_3)$ on T^α and $\psi^b(x) = (x_1, 0, 0)$ on S^b . 

It remains to prove that

$$\psi^\alpha(0) = \psi^b(0). \quad (3.37)$$

The junction condition (3.37) is obtained passing to the limit, as $\varepsilon \rightarrow 0$, in

$$\int_{(-\frac{1}{2}, \frac{1}{2})^2} \psi^\alpha(\varepsilon)(x_1, x_2, 0) \, dx_1 \, dx_2 = \int_{(-\frac{1}{2}, \frac{1}{2})^2} \psi^b(\varepsilon)(\varepsilon x_1, x_2, 0) \, dx_1 \, dx_2 \quad (3.38)$$

and this can be done by arguing as in [41]. We sketch here an alternate proof as follows.

The sequence of traces $\psi^\alpha(\varepsilon)(\cdot, 0)$ is compact in $L^q\left(\left(-\frac{1}{2}, \frac{1}{2}\right)^2\right)$ as a consequence of the weak convergence of $\psi^\alpha(\varepsilon)$ in $W^{1,p}(\Omega^\alpha)$, provided by (3.35) and, the compact inclusion of the traces of $W^{1,p}(\Omega^\alpha)$ in $L^q\left(\left(-\frac{1}{2}, \frac{1}{2}\right)^2\right)$ for some $q > 1$ which is true if $p > 2$ and for which we refer to Biegert [?]. Passing to the limit on the left-hand side we obtain

$$\lim_{\varepsilon \rightarrow 0} \int_{(-\frac{1}{2}, \frac{1}{2})^2} \psi^\alpha(\varepsilon)(x_1, x_2, 0) \, d(x_1, x_2) = \psi^\alpha(0), \quad (3.39)$$

since, we have observed, following (3.36), that ψ^α is constant with respect to x_1 and x_2 .

Similarly, the sequence of traces $\psi^b(\varepsilon)(\cdot, 0)$ is compact in $L^q\left(\left(-\frac{1}{2}, \frac{1}{2}\right)^2\right)$ and notice that

$\psi^b(\varepsilon x_1, x_2, 0) \rightarrow \psi^b(0, x_2, 0)$ strongly. But this is not enough to pass to the limit on the right-hand side of (3.38) because of the concentration of the argument near $x_1 = 0$. Actually, this indicates that some convergence in the space of continuous functions will be necessary. Also, it is worth mentioning that the estimates in (3.33) will be quite important. We only sketch here the main ideas for establishing this limit while referring the reader to Proposition 2.1 [41] for the details and the precise manner of obtaining the necessary estimates. The question can be settled if one has the strong sequence of the traces $\psi^b(\varepsilon)(\cdot, 0)$ in $C\left(\left(-\frac{1}{2}, \frac{1}{2}\right)^2\right)$ but this is not guaranteed. However, it turns out that this is sufficient to find at least a height, $x_3 \in [-1, 0]$, at which the traces $\psi^b(\varepsilon)(\cdot, x_3^*)$ are bounded and therefore, compact in $C\left(\left(-\frac{1}{2}, \frac{1}{2}\right)^2\right)$ provided $p > 2$. Then, to calculate the limit on the right hand side of (3.38) we write

$$\begin{aligned} & \int_{\left(-\frac{1}{2}, \frac{1}{2}\right)^2} \psi^b(\varepsilon)(\varepsilon x_1, x_2, 0) d(x_1, x_2) \\ &= \int_{\left(-\frac{1}{2}, \frac{1}{2}\right)^2} (\psi^b(\varepsilon)(\varepsilon x_1, x_2, 0) - \psi^b(\varepsilon)(\varepsilon x_1, x_2, x_3^*)) d(x_1, x_2) + \int_{\left(-\frac{1}{2}, \frac{1}{2}\right)^2} \psi^b(\varepsilon)(\varepsilon x_1, x_2, x_3^*) d(x_1, x_2) \end{aligned} \quad (3.40)$$

Then, it can be shown that the first term on the right hand side in the above goes to 0 as $\varepsilon \rightarrow 0$ using the estimates in (3.33). Whereas, the second integral converges to $\psi^b(0)$ since we have the strong convergence of $\psi^b(\varepsilon)(\varepsilon x_1, x_2, x_3^*)$ to $\psi^b(0, x_2, x_3^*)$ in $C\left(\left(-\frac{1}{2}, \frac{1}{2}\right)^2\right)$ and $\psi^b(0, x_2, x_3^*)$ is constant in x_2 and x_3 . At last, we obtain

$$\lim_{\varepsilon \rightarrow 0} \int_{\left(-\frac{1}{2}, \frac{1}{2}\right)^2} \psi^b(\varepsilon)(\varepsilon x_1, x_2, 0) d(x_1, x_2) = \psi^b(0). \quad (3.41)$$

Thus, from (3.39) and (3.41) the desired conclusion (3.37) follows.

Finally, if u^a and u^b denote the corresponding limits of the sequences $u^a(\varepsilon)$ and $u^b(\varepsilon)$ respectively, since $u^a(x) = \psi^a(x) - (0, 0, x_3)$, $u^b(x) = \psi^b - (x_1, 0, 0)$, then u^a is independent of (x_1, x_2) , u^b is independent of (x_2, x_3) , $u^a(x) = 0$ on T^a , $u^b(x) = 0$ on S^b and $u^a(0) = u^b(0)$ follows directly from (3.37). Therefore, $(u^a, u^b) \in V_J$. ■

PROPOSITION 3.3.1. *For all $(v^a(\varepsilon), v^b(\varepsilon)) \in \mathcal{Z}^p$, such that $(v^a(\varepsilon), v^b(\varepsilon)) \rightarrow (v^a, v^b)$ strongly in $L^p(\Omega^a; \mathbb{R}^3) \times L^p(\Omega^b; \mathbb{R}^3)$, then for $(v^a, v^b) \in V_J$, we have that*

$$\begin{aligned} \liminf_{\varepsilon \rightarrow 0} \tilde{J}(\varepsilon)((v^a(\varepsilon), v^b(\varepsilon))) &\geq \int_0^1 W_a^{**} \left(e_3 + \frac{d\bar{v}^a}{dx_3} \right) dx_3 + \int_{-1/2}^{1/2} W_b^{**} \left(e_1 + \frac{d\bar{v}^b}{dx_1} \right) dx_1 \\ &\quad - \int_0^1 \bar{g}^a \cdot ((0, 0, x_3) + \bar{v}^a) dx_3 - \int_{-1/2}^{1/2} \bar{g}^b \cdot ((x_1, 0, 0) + \bar{v}^b) dx_1 \end{aligned} \quad (3.42)$$

Proof. If $\liminf_{\varepsilon \rightarrow 0} \tilde{J}(\varepsilon)((v^a(\varepsilon), v^b(\varepsilon))) = +\infty$ there is nothing to prove. Without loss of generality we

assume that $\tilde{J}(\varepsilon)((v^a(\varepsilon), v^b(\varepsilon)))$ is bounded from above. It follows from Lemma 3.1 that $(v^a, v^b) \in V_J$. Also, it is clear from the assumption (3.15) that, when $\varepsilon \rightarrow 0$,

$$\begin{aligned} & \int_{\Sigma^a} g^a(\varepsilon) \cdot ((0, 0, x_3) + v^a(\varepsilon)) d\zeta + \int_{\Sigma^b} g^b(\varepsilon) \cdot ((x_1, 0, 0) + v^b(\varepsilon)) d\zeta \\ & \longrightarrow \int_{\Sigma^a} g^a \cdot ((0, 0, x_3) + v^a) d\zeta + \int_{\Sigma^b} g^b \cdot ((x_1, 0, 0) + v^b) d\zeta \\ & = \int_0^1 \bar{g}^a \cdot ((0, 0, x_3) + \bar{v}^a) dx_3 - \int_{-1/2}^{1/2} \bar{g}^b \cdot ((x_1, 0, 0) + \bar{v}^b) dx_1. \end{aligned} \quad (3.43)$$

For the elastic energy, we have that (with $\psi^a(\varepsilon) = v^a(\varepsilon) + r_\varepsilon$ and $\psi^b(\varepsilon) = v^b(\varepsilon) + s_\varepsilon$ as usual)

$$\begin{aligned} \int_{\Omega^a} W \left(\left(\frac{1}{\varepsilon} \partial_1 \psi^a(\varepsilon) \middle| \frac{1}{\varepsilon} \partial_2 \psi^a(\varepsilon) \middle| \partial_3 \psi^a(\varepsilon) \right) \right) dx & \geq \int_{\Omega^a} W_a((\partial_3 \psi^a(\varepsilon))) dx \\ & \geq G^a(\psi^a(\varepsilon)) = \int_{\Omega^a} W_a^{**}((\partial_3 \psi^a(\varepsilon))) dx, \end{aligned} \quad (3.44)$$

$$\begin{aligned} \int_{\Omega^b} W \left(\left(\partial_1 \psi^b(\varepsilon) \middle| \frac{1}{\varepsilon} \partial_2 \psi^b(\varepsilon) \middle| \frac{1}{\varepsilon} \partial_3 \psi^b(\varepsilon) \right) \right) dx & \geq \int_{\Omega^b} W_b((\partial_1 \psi^b(\varepsilon))) dx \\ & \geq G^b(\psi^b(\varepsilon)) = \int_{\Omega^b} W_b^{**}((\partial_1 \psi^b(\varepsilon))) dx. \end{aligned} \quad (3.45)$$

Therefore, due to the lower semicontinuity of the integral functionals G^a and G^b on $W^{1,p}(\Omega^a; \mathbb{R}^3)$ and $W^{1,p}(\Omega^b; \mathbb{R}^3)$ respectively and since $\psi^a(\varepsilon) \rightharpoonup \psi^a = v^a + r_0$ weakly in $W^{1,p}(\Omega^a; \mathbb{R}^3)$ and $\psi^b(\varepsilon) \rightharpoonup \psi^b = v^b + s_0$ weakly in $W^{1,p}(\Omega^b; \mathbb{R}^3)$ by virtue of Lemma 3.1, then we have that

$$\liminf_{\varepsilon \rightarrow 0} \int_{\Omega^a} W \left(\left(\frac{1}{\varepsilon} \partial_1 \psi^a(\varepsilon) \middle| \frac{1}{\varepsilon} \partial_2 \psi^a(\varepsilon) \middle| \partial_3 \psi^a(\varepsilon) \right) \right) dx \geq G^a(\psi^a) = \int_0^1 W_a^{**}(e_3 + \partial_3 \bar{v}^a) dx_3 \quad (3.46)$$

and

$$\liminf_{\varepsilon \rightarrow 0} \int_{\Omega^b} W \left(\left(\partial_1 \psi^b(\varepsilon) \middle| \frac{1}{\varepsilon} \partial_2 \psi^b(\varepsilon) \middle| \frac{1}{\varepsilon} \partial_3 \psi^b(\varepsilon) \right) \right) dx \geq G^b(\psi^b) = \int_{-1/2}^{1/2} W_b^{**}(e_1 + \partial_1 \bar{v}^b) dx_1. \quad (3.47)$$

Finally, using $v^a(\varepsilon) = \psi^a(\varepsilon) - r_\varepsilon$ and $v^b(\varepsilon) = \psi^b(\varepsilon) - s_\varepsilon$ on right-hand side of inequalities (3.46) and (3.47), the inequality for a sum of \liminf and (3.43) the proof is complete. \blacksquare

PROPOSITION 3.3.2. *For all $(v^a, v^b) \in V_J$ and $((w_2, \zeta_2), (w_1, \zeta_3)) \in \bar{V}_J \times \bar{V}_J$, there exist a sequence $(v^a(\varepsilon), v^b(\varepsilon)) \in L^p(\Omega^a; \mathbb{R}^3) \times L^p(\Omega^b; \mathbb{R}^3)$ which converges strongly to (v^a, v^b) such that sequence*

$\tilde{J}(\varepsilon)((v^a(\varepsilon), v^b(\varepsilon)))$ converges and satisfies

$$\begin{aligned} \lim_{\varepsilon \rightarrow 0} \tilde{J}(\varepsilon)((v^a(\varepsilon), v^b(\varepsilon))) &\leq \int_0^1 W((e_1 + w_1|e_2 + w_2|e_3 + \partial_3 \bar{v}^a)) \, dx_3 \\ &\quad + \int_{-1/2}^{1/2} W\left(\left(e_1 + \partial_1 \bar{v}^b|e_2 + \zeta_2|e_3 + \zeta_3\right)\right) \, dx_1 \\ &\quad - \int_0^1 \bar{g}^a \cdot ((0, 0, x_3) + \bar{v}^a) \, dx_3 - \int_{-1/2}^{1/2} \bar{g}^b \cdot ((x_1, 0, 0) + \bar{v}^b) \, dx_1. \end{aligned} \quad (3.48)$$

Proof. Given $(v^a, v^b) \in V_J$ and $((w_2, \zeta_2), (w_1, \zeta_3)) \in \bar{V}_J \times \bar{V}_J$ we define the displacements:

$$v^a(\varepsilon)(x) = \begin{cases} \bar{v}^a(x_3) + \varepsilon x_2 w_2(x_3) + \varepsilon x_1 w_1(x_3), & \text{if } x \in (-\frac{1}{2}, \frac{1}{2})^2 \times (\varepsilon, 1), \\ \frac{x_3}{\varepsilon} (\bar{v}^a(\varepsilon) + \varepsilon x_2 w_2(\varepsilon) + \varepsilon x_1 w_1(\varepsilon)) \\ + \frac{\varepsilon - x_3}{\varepsilon} [\bar{v}^b(\varepsilon x_1) + \varepsilon x_2 \zeta_2(\varepsilon x_1) + \varepsilon x_3 \zeta_3(\varepsilon x_1)] & \text{if } x \in (-\frac{1}{2}, \frac{1}{2})^2 \times [0, \varepsilon] \end{cases} \quad (3.49)$$

$$v^b(\varepsilon)(x) = \bar{v}^b(x_1) + \varepsilon x_2 \zeta_2(x_1) + \varepsilon x_3 \zeta_3(x_1) \quad \text{if } x \in (-\frac{1}{2}, \frac{1}{2})^2 \times (-1, 0), \quad (3.50)$$

choice which is inspired both by Gaudiello *et al.* and by [58]. It can be checked that $(v^a(\varepsilon)(x), v^b(\varepsilon)(x)) \in V(\varepsilon)$ and $v^a(\varepsilon) \rightarrow v^a$ strongly in $W^{1,p}(\Omega^a; \mathbb{R}^3)$ and $v^b(\varepsilon) \rightarrow v^b$ strongly in $W^{1,p}(\Omega^b; \mathbb{R}^3)$. Finally, by an application of the dominated convergence theorem and the growth estimate one derives that

$$\begin{aligned} \lim_{\varepsilon \rightarrow 0} \tilde{J}(\varepsilon)((v^a(\varepsilon), v^b(\varepsilon))) &= \int_0^1 W((e_1 + w_1|e_2 + w_2|e_3 + \partial_3 \bar{v}^a)) \, dx_3 \\ &\quad + \int_{-1/2}^{1/2} W\left(\left(e_1 + \partial_1 \bar{v}^b|e_2 + \zeta_2|e_3 + \zeta_3\right)\right) \, dx_1 \\ &\quad - \int_0^1 \bar{g}^a \cdot ((0, 0, x_3) + \bar{v}^a) \, dx_3 - \int_{-1/2}^{1/2} \bar{g}^b \cdot ((x_1, 0, 0) + \bar{v}^b) \, dx_1. \end{aligned}$$

■

The proof of Theorem 2.2 It is well known that in a separable metric space, the sequence $\tilde{J}(\varepsilon)$ always has a Γ -convergent subsequence (see [13]). We shall now show that any Γ -limit coincides with $\tilde{J}(0)$ defined in subsection 3.2.4 which implies that the entire sequence Γ -converges to $\tilde{J}(0)$ proving the theorem.

To begin, we consider a subsequence of $\tilde{J}(\varepsilon)$ which Γ -converges and for convenience, index it by ε .

Also let \bar{J} be the Γ -limit of this subsequence. By the definition of Γ -convergence (see Braides [12]):

$$\begin{aligned}\bar{J}(v) &= \inf\{\liminf_{\varepsilon \rightarrow 0} \tilde{J}(\varepsilon)(v(\varepsilon)) : v(\varepsilon) \rightarrow v \in L^p(\Omega^a; \mathbb{R}^3) \times L^p(\Omega^b; \mathbb{R}^3)\} \\ &= \inf\{\limsup_{\varepsilon \rightarrow 0} \tilde{J}(\varepsilon)(v(\varepsilon)) : v(\varepsilon) \rightarrow v \in L^p(\Omega^a; \mathbb{R}^3) \times L^p(\Omega^b; \mathbb{R}^3)\}.\end{aligned}$$

By Proposition 3.3.1, it follows, by taking the infimum over all sequences $v(\varepsilon)$ that converge to v in $L^p(\Omega^a; \mathbb{R}^3) \times L^p(\Omega^b; \mathbb{R}^3)$, that

$$\bar{J}(v) \geq \tilde{J}(0)(v) \text{ for all } v \in L^p(\Omega^a; \mathbb{R}^3) \times L^p(\Omega^b; \mathbb{R}^3). \quad (3.51)$$

To prove the reverse inequality, we shall use Proposition 3.3.2. It is enough to consider $(v^a, v^b) \in V_J$. For such a v and for different choices of $((w_2, \zeta_2), (w_1, \zeta_3))$ belonging to $\bar{V}_J \times \bar{V}_J$, we can construct sequences $(v^a(\varepsilon), v^b(\varepsilon))$ converging to (v^a, v^b) strongly in $W^{1,p}(\Omega^a; \mathbb{R}^3) \times W^{1,p}(\Omega^b; \mathbb{R}^3)$ for which (3.48) of Proposition 3.3.2 holds. So, taking the infimum over all such sequences and using once again the definition of the Γ -limit, we get

$$\begin{aligned}\bar{J}(v^a, v^b) &\leq \inf_{(v^a(\varepsilon), v^b(\varepsilon)) \rightarrow (v^a, v^b)} \lim_{\varepsilon \rightarrow 0} \tilde{J}(\varepsilon)((v^a(\varepsilon), v^b(\varepsilon))) \\ &\leq \inf_{((w_2, \zeta_2), (w_1, \zeta_3)) \in \bar{V}_J \times \bar{V}_J} \left(\int_0^1 W((e_1 + w_1|e_2 + w_2|e_3 + \partial_3 \bar{v}^a)) dx_3 \right. \\ &\quad \left. + \int_{-1/2}^{1/2} W((e_1 + \partial_1 \bar{v}^b|e_2 + \zeta_2|e_3 + \zeta_3)) dx_1 - \int_0^1 \bar{g}^a \cdot ((0, 0, x_3) + \bar{v}^a) dx_3 \right. \\ &\quad \left. - \int_{-1/2}^{1/2} \bar{g}^b \cdot ((x_1, 0, 0) + \bar{v}^b) dx_1 \right). \quad (3.52)\end{aligned}$$

However, by the density of $W_a^{1,p}((0, 1); \mathbb{R}^3)$ and $W_b^{1,p}((-\frac{1}{2}, \frac{1}{2}); \mathbb{R}^3)$ in $L^p((0, 1); \mathbb{R}^3)$ and $L^p((-\frac{1}{2}, \frac{1}{2}); \mathbb{R}^3)$, respectively, we have

$$\begin{aligned}&\inf_{(w_1, w_2) \in W_a^{1,p}((0, 1); \mathbb{R}^3) \times W_b^{1,p}((0, 1); \mathbb{R}^3)} \int_0^1 W((e_1 + w_1|e_2 + w_2|\partial_3 \bar{\psi}^a)) dx_3 \\ &= \inf_{(w_1, w_2) \in L^p((0, 1); \mathbb{R}^3) \times L^p((0, 1); \mathbb{R}^3)} \int_0^1 W((e_1 + w_1|e_2 + w_2|\partial_3 \bar{\psi}^a)) dx_3 \quad (3.53)\end{aligned}$$

and

$$\begin{aligned} & \inf_{(\zeta_2, \zeta_3) \in W_b^{1,p}((-\frac{1}{2}, \frac{1}{2}); \mathbb{R}^3) \times W_b^{1,p}((-\frac{1}{2}, \frac{1}{2}); \mathbb{R}^3)} \int_{-1/2}^{1/2} W\left(\left(\partial_1 \overline{\psi^b} | e_2 + \zeta_2 | e_3 + \zeta_3\right)\right) dx_1 \\ &= \inf_{(\zeta_2, \zeta_3) \in L^p((-\frac{1}{2}, \frac{1}{2}); \mathbb{R}^3) \times L^p((-\frac{1}{2}, \frac{1}{2}); \mathbb{R}^3)} \int_{-1/2}^{1/2} W\left(\left(\partial_1 \overline{\psi^b} | e_2 + \zeta_2 | e_3 + \zeta_3\right)\right) dx_1. \end{aligned} \quad (3.54)$$

Let

$$K^a(x, z_1, z_2) := W\left(e_1 + z_1 | e_2 + z_2 | e_3 + \partial_3 \overline{v^a}(x)\right)$$

and

$$K^b(x, z_2, z_3) := W\left(e_1 + \partial_3 \overline{v^b}(x) | e_2 + z_2 | e_3 + z_3\right).$$

These are Carathéodory functions and the measurable selection lemma *cf.* [34] shows that there exist measurable functions w_1^* , w_2^* , ζ_2^* and ζ_3^* such that

$$\begin{cases} W_a(e_3 + \partial_3 \overline{v^a}(x)) = W\left(\left(e_1 + w_1^*(x) | e_2 + w_2^*(x) | e_3 + \partial_3 \overline{v^a}(x)\right)\right) \text{ for almost all } x \in (0, 1), \\ W_b(e_1 + \partial_1 \overline{v^b}(x)) = W\left(\left(e_1 + \partial_1 \overline{v^b}(x) | e_2 + \zeta_2^*(x) | e_3 + \zeta_3^*(x)\right)\right) \text{ for almost all } x \in (-\frac{1}{2}, \frac{1}{2}). \end{cases} \quad (3.55)$$

From the coercivity of W , we can deduce that $(w_1^*, w_2^*, \zeta_2^*, \zeta_3^*) \in L^p((0, 1); \mathbb{R}^3)^2 \times L^p((-\frac{1}{2}, \frac{1}{2}); \mathbb{R}^3)^2$. Now, from (3.52)-(3.55), it can be deduced that

$$\begin{aligned} \bar{J}(v^a, v^b) &\leq \int_0^1 W_a\left(e_3 + \frac{d\overline{v^a}}{dx_3}\right) dx_3 + \int_{-1/2}^{1/2} W_b\left(e_1 + \frac{d\overline{v^b}}{dx_1}\right) dx_1 \\ &\quad - \int_0^1 \overline{g}^a \cdot ((0, 0, x_3) + \overline{v^a}) dx_3 - \int_{-1/2}^{1/2} \overline{g}^b \cdot ((x_1, 0, 0) + \overline{v^b}) dx_1 \end{aligned}$$

The Γ -limit \bar{J} is always lower semi-continuous and so by the above inequality, it is less than the lower semi-continuous envelope of the right hand side which is exactly the right hand side in (3.23). ■

3.4 An example

We conclude this article by examining the case of the Saint-Venant-Kirchhoff material in detail. Recall that the Saint-Venant-Kirchhoff stored energy function is given by

$$W(F) = \frac{\mu}{4} \operatorname{tr} (F^T F - I)^2 + \frac{\lambda}{8} \left(\operatorname{tr} (F^T F - I) \right)^2, \quad \forall F \in \mathbb{R}^{3 \times 3},$$

where μ and λ are the Lamé moduli, which we assume to be such that $\mu > 0$ and $\lambda \geq 0$.

This W has the following properties required of hyperelastic three-dimensional bodies which are:

(a) *Objectivity or material frame-indifference principle:*

$$\forall F \in \mathbb{R}^{3 \times 3}, \quad \forall R \in \operatorname{SO}(3), \quad W(RF) = W(F). \quad (3.56)$$

(b) *Natural state:* $W(I) = \min W = 0$.

We did not consider these properties during the process of obtaining the variational limit of the three dimensional model since it does not affect the convergence analysis. However, these properties have a consequence on the stored energy of the one dimensional model. In fact, it has been shown in Acerbi et al. [1] that when these hold for W then $W_a(z)$ and $W_b(z)$ will depend only on $|z|$ and moreover, W_a^{**} and W_b^{**} necessarily vanish on the unit ball in \mathbb{R}^3 . We now obtain the explicit expressions of W_a^{**} and W_b^{**} .

PROPOSITION 3.4.1. *For the Saint-Venant-Kirchhoff stored energy function, we have*

$$W_b(z) = W_a(z) = \frac{\mu(3\lambda + 2\mu)}{8(\lambda + \mu)} h^2(z) + \frac{1}{8(\lambda + \mu)} ([\lambda h(z) - 2(\lambda + \mu)]_+)^2, \quad (3.57)$$

where $h(z) = (|z|^2 - 1)$ and the junction energies are given by

$$W_a^{**}(z) = W_b^{**}(z) = \frac{E}{8} ([|z|^2 - 1]_+)^2 + \frac{E}{4(1 + \nu)(1 - 2\nu)} ([\nu |z|^2 - (1 + \nu)]_+)^2 \quad (3.58)$$

respectively, where $|z| \geq 0$ is the norm of $z \in \mathbb{R}^{3 \times 1}$ and $E = \frac{\mu(3\lambda + 2\mu)}{\lambda + \mu}$ is the Young modulus and $\nu = \frac{\lambda}{2(\mu + \lambda)}$ is the Poisson's ratio.

Proof. For calculating W_a , let us first express $W(F)$ in terms of the column vectors of F :

$$\begin{aligned}
W(F) &= \frac{\mu}{4} \left(\sum_{i,j=1}^3 (z_i \cdot z_j - \delta_{ij})^2 \right) + \frac{\lambda}{8} \left(\sum_{i=1}^3 (|z_i|^2 - 1) \right)^2 \\
&= \frac{\mu}{4} \left(\sum_{\alpha,\beta=1}^2 (z_\alpha \cdot z_\beta - \delta_{\alpha\beta})^2 \right) + \frac{\lambda}{8} \left(\sum_{\alpha=1}^2 (|z_\alpha|^2 - 1) \right)^2 + \frac{\mu}{2} \left(\sum_{\alpha=1}^2 (z_\alpha \cdot z_3)^2 \right) \\
&\quad + \frac{(2\mu + \lambda)}{8} (|z_3|^2 - 1)^2 + \frac{\lambda}{4} (|z_3|^2 - 1) \left(\sum_{\alpha=1}^2 |z_\alpha|^2 - 1 \right). \tag{3.59}
\end{aligned}$$

By an inspection of (3.59), it is clear that in order to minimize $W((\bar{F}|z_3))$ with respect to $\bar{F} = (z_1|z_2)$, we need to choose $\{z_1, z_2, z_3\}$ as a orthogonal set. If we now set $t = |z_1|$ and $s = |z_2|$, then we are left with minimizing the function

$$\begin{aligned}
f(s, t) &= \frac{2\mu + \lambda}{8} [(s^2 - 1)^2 + (t^2 - 1)^2] + \frac{\lambda}{4} [(s^2 - 1) + (t^2 - 1)] (|z_3|^2 - 1) \\
&\quad + \frac{\lambda}{4} (s^2 - 1)(t^2 - 1) \tag{3.60}
\end{aligned}$$

over the set $\{(s, t) \in \mathbb{R}^2 : s \geq 0 \wedge t \geq 0\}$ with $|z_3|$ as a parameter. Letting $x = s^2 - 1$, $y = t^2 - 1$ and $h = (|z_3|^2 - 1)$, we need to minimize the function

$$g(x, y) = \frac{\lambda + 2\mu}{8} (x^2 + y^2) + \frac{\lambda}{4} (x + y)h + \frac{\lambda}{4} xy \tag{3.61}$$

over the set $\Lambda = \{(x, y) \in \mathbb{R}^2 : x \geq -1 \wedge y \geq -1\}$. The eigenvalues of this function are $\frac{\mu}{4}$ and $\frac{\lambda + \mu}{4}$ which are non-negative by the hypotheses on λ and μ and so this is a positive definite quadratic form. The unique critical point of the quadratic form on \mathbb{R}^2 is

$$(x_0, y_0) = \left(-\frac{\lambda}{2(\lambda + \mu)} h, -\frac{\lambda}{2(\lambda + \mu)} h \right). \tag{3.62}$$

We now need to analyze two cases. When the critical point belongs to Λ , which happens if and only if $h \leq \frac{2(\lambda + \mu)}{\lambda}$, the minimum of g is attained at (x_0, y_0) . For $h > \frac{2(\lambda + \mu)}{\lambda}$, it can be shown that the minimum of g is achieved in $(-1, -1)$. Therefore,

$$\min g = \begin{cases} g(x_0, y_0) = -\frac{\lambda^2}{8(\lambda + \mu)} h^2 & \text{if } h \leq \frac{2(\lambda + \mu)}{\lambda}, \\ g(-1, -1) = \frac{\lambda + \mu}{2} - \frac{\lambda}{2} h & \text{if } h > \frac{2(\lambda + \mu)}{\lambda}. \end{cases} \tag{3.63}$$

Then, the value of $W_a(z_3)$ as stated in (3.57) is obtained by adding the term $\frac{(2\mu+\lambda)}{8}(|z_3|^2 - 1)^2$ to $\min g$ in (3.63) which only depends on z_3 and there after performing a simple calculation.

We now compute the convex envelope W_a^{**} of W_a . We observe that W_a is non-negative and takes its minimum value at all $z \in \mathbb{R}^3$ with norm 1. Moreover, it is convex for $|z| \geq 1$. So, the convex envelope is given by expression (3.58). ■



Bibliography

- [1] E. ACERBI, G. BUTTAZZO AND D. PERCIVALE, A variational definition of the strain energy for an elastic string. *J. Elasticity*. **25** (1991), 137-148.
- [2] Y. ACHDOU, N. TCHOU, Hamilton-Jacobi equations on networks as limits of singularly perturbed problems in optimal control: dimension reduction. *Comm. Partial Differential Equations* **40** (2015), 652-693.
- [3] A.K. AL SAYED, G. CARBOU, S. LABBÉ, Asymptotic model for twisted bent ferromagnetic wires with electric current. *Z. Angew. Math. Phys.* **70** (2019), no. 1, Art. 6, 15 pp.
- [4] Y. AMIRAT, R. TOUZANI, A circuit equation as a limit of eddy current. *Arch. Ration. Mech. Anal.* **226** (2017), 405-440.
- [5] G. ANZELLOTTI, S. BALDO, Asymptotic development by Γ -convergence. *Appl. Math. Optim.* **27** (1993) 105-123.
- [6] G. ANZELLOTTI, S. BALDO, D. PERCIVALE, Dimensional reduction in variational problems, asymptotic developments in Γ -convergence, and thin structures in elasticity. *Asymptotic Anal.* **9** (1994), 61-100.
- [7] J.F. BABADJIAN, M. BAÍA, 3D-2D analysis of a thin film with periodic microstructure. *Proceedings of the Royal Society of Edinburgh, Section A* **136** no. **2**, (2006) 223-243.

- [8] J. BALL, Convexity conditions and existence theorems in nonlinear elasticity. *Arch. Rational Mech. Anal.* **63** (1977), 337-403.
- [9] J. BALLATO, M. C. GUPTA (EDITORS), The Handbook of photonics, Second Edition, CRC Press 2006. V. Gopalan, K. L. Schepler, V. Dierolf, I. Biaggio, Chapter 6. Ferroelectric Materials.
- [10] M. BIEGERT, On traces of Sobolev functions on the boundary of extension domains. *Proc. Amer. Math. Soc.* **137**, No. 12 (2009), 4169–4176.
- [11] D. BLANCHARD, G. GRISO, Asymptotic behavior of structures made of straight rods. *J. Elasticity* **108**, No. 1 (2012), 85-118 .
- [12] A. BRAIDES, Γ -convergence for beginners. *Oxford Lecture Series in Mathematics and its Applications*, **22**. Oxford University Press, Oxford, 2002.
- [13] A. BRAIDES, A handbook of Γ -convergence. *In Handbook of Differential Equations. Stationary Partial Differential Equations*, Volume 3 (M. Chipot and P. Quittner, eds.), Elsevier, 2006.
- [14] A. BRAIDES, I. FONSECA, G. FRANFORT, 3D-2D asymptotic analysis for inhomogeneous thin films . *Indiana Univ. Math. J.* **49**, (2000) 1367-1404.
- [15] R. BUNOIU, A. GAUDIELLO, A. LEOPARDI, Asymptotic analysis of a Bingham fluid in a thin T-like shaped structure. *J. Math. Pures Appl. (9)* **123** (2019), 148-166.
- [16] L. CARBONE, K. CHACOUCHE, A. GAUDIELLO, Fin junction of ferroelectric thin films. *Adv. Calc. Var.* **11** (2018), 4, 341-371.
- [17] L. CARBONE, R. DE ARCANGELIS, Unbounded functionals in the calculus of variations. Representation, relaxation, and homogenization. *Chapman & Hall/CRC Monographs and Surveys in Pure and Applied Mathematics*, **125**. Chapman & Hall/CRC, Boca Raton, FL, 2002.
- [18] L. CARBONE, A. GAUDIELLO, P. HERNÁNDEZ-LLANOS, T-junction of ferroelectric wires. *ESAIM Math. Model. Numer. Anal.* **54** (2020), 5, 1429-1463.
- [19] G. CARBOU, S. LABBÉ, Stabilization of walls for nano-wires of finite length. *ESAIM Control Optim. Calc. Var.* **18** (2012), 1-21.
- [20] K. CHACOUCHE, L. FAELLA, C. PERUGIA, Quasi-stationary ferromagnetic problem for thin multi-structures. *Rev. Mat. Complut.* **30** (2017), 657-685.
- [21] K. CHACOUCHE, L. FAELLA, C. PERUGIA, Junction of quasi-stationary ferromagnetic wires. *Atti Accad. Naz. Lincei Rend. Lincei Mat. Appl.*, to appear.

- [22] P. CHANDRA, P.B. LITTLEWOOD, A Landau primer for ferroelectrics, *The Physics of ferroelectrics: A modern perspective*, edited by K. Rabe, C.H. Ahn and J.-M. Triscone. *Topics Appl. Phys.* **105** (2007) 69-116.
- [23] P.G. CIARLET, *Plates and Junctions in Elastic Multi-Structures: An asymptotic Analysis*. Masson, Paris (1990).
- [24] P.G. CIARLET, "Mathematical elasticity. Vol. I. Three-dimensional elasticity" . *Studies in Mathematics and its Applications*, **20**. North-Holland Publishing Co., Amsterdam (1988).
- [25] P.G. CIARLET, "Mathematical elasticity. Vol. II. Theory of plates" . *Studies in Mathematics and its Applications*, **27**. North-Holland Publishing Co., Amsterdam (1997).
- [26] P. G. CIARLET, "Mathematical elasticity. Vol. III. Theory of shells" . *STUDIES IN MATHEMATICS AND ITS APPLICATIONS*, **29**. North-Holland Publishing Co., Amsterdam (2000).
- [27] P.G. CIARLET, *Linear and nonlinear functional analysis with applications. Society for Industrial and Applied Mathematics, Philadelphia, PA, 2013*.
- [28] P.G. CIARLET, P. DESTUYNDER, A justification of the two-dimensional linear plate model. *J. Mécanique* **18** (1979), 2, 315-344.
- [29] M. COSTABEL, M. DAUGE, S. NICAISE, Singularities of Maxwell interface problems. *M2AN Math. Model. Numer. Anal.* **33** (1999), 627-649.
- [30] L. E. CROSS, R. E. NEWNHAM, History of ferroelectrics, Reprinted from the *Ceramics and Civilization, Volume III High-Technology Ceramics-Past, Present, and Future*. Copyright 1987 by The American Ceramic Society. Inc.
- [31] B. DACAROGNA, *Direct Methods in the Calculus of Variations. Applied Mathematical Sciences*, No. **78**, Springer-Verlag, Berlin, (1989).
- [32] G. DAL MASO, An introduction to Γ -convergence. *Progress in Nonlinear Differential Equations and their Applications*, **8**. Birkhäuser Boston, Inc., Boston, MA, 1993.
- [33] E. DE GIORGI, T. FRANZONI, Su un tipo di convergenza variazionale. *Atti Accad. Naz. Lincei Rend. Cl. Sci. Fis. Mat. Natur.* **58** (8) (1975), 6, 842-850.
- [34] I. EKELAND, R. TEMAM, *Analyse convexe et problèmes variationnels*. Dunod, Paris, (1974).
- [35] E. EL BACHARI, Modélisation d'une jonction 3d–2d en élasticité non linéaire par Γ –convergence. *C. R. Acad. Paris I*, t.**325**, Série I (1997), 1241-1246.

- [36] R. FERREIRA, E. ZAPPALE, Bending-torsion moments in thin multi-structures in the context of nonlinear elasticity. arXiv:1712.02598v1 [math.AP].
- [37] G. FRIESECKE, R.D. JAMES, M.G. MORA, S. MÜLLER, Derivation of nonlinear bending theory for shells from three-dimensional nonlinear elasticity by Gamma-convergence. *C. R. Math. Acad. Sci. Paris* **336**(8) (2003) 697–702.
- [38] G. FRIESECKE, R.D. JAMES, S. MÜLLER, A theorem on geometric rigidity and the derivation of nonlinear plate theory from three-dimensional elasticity. *Commun. Pure Appl. Math.* **55**(11) (2002) 1461–1506.
- [39] G. FRIESECKE, R.D. JAMES, S. MÜLLER, The Föppl-von Kármán plate theory as a low energy Γ -limit of nonlinear elasticity. *C. R. Math. Acad. Sci. Paris* **335** (2002), 201-206.
- [40] G. FRIESECKE, R.D. JAMES, S. MÜLLER, A hierarchy of plate models derived from nonlinear elasticity by gamma-convergence. *Arch. Ration. Mech. Anal.* **180**(2) (2006) 183–236.
- [41] A. GAUDIELLO, B. GUSTAFSSON, C. LEFTER, J. MOSSINO, Asymptotic analysis of a class of minimization problems in a thin multidomain. *Calc. Var. Partial Differential Equations* **15** (2) (2002), 181-201.
- [42] A. GAUDIELLO, R. HADIJI, Junction of one-dimensional minimization problems involving S^2 valued maps. *Adv. Differ. Equ.* **13** (2008), 9-10, 935-958.
- [43] A. GAUDIELLO, R. HADIJI, Asymptotic analysis, in a thin multidomain, of minimizing maps with values in S^2 . *Ann. Inst. Henri Poincaré, Anal. Non Linéaire* **26** (2009), 1, 59-80.
- [44] A. GAUDIELLO, R. HADIJI, Junction of ferromagnetic thin films. *Calc. Var. Partial Differential Equations* **39** (2010), 3, 593-619.
- [45] A. GAUDIELLO, R. HADIJI, Ferromagnetic thin multi-structures. *J. Differential Equations* **257** (2014), 1591-1622.
- [46] A. GAUDIELLO, K. HAMDACHE, The polarization in a ferroelectric thin film: local and nonlocal limit problems. *ESAIM Control Optim. Calc. Var.* **19** (2013), 657-667.
- [47] A. GAUDIELLO, K. HAMDACHE, A reduced model for the polarization in a ferroelectric thin wire. *NoDEA Nonlinear Differential Equations Appl.* **22** (2015), 1883-1896.
- [48] A. GAUDIELLO, R. MONNEAU, J. MOSSINO, F. MURAT, A. SILI, Junction of elastic plates and beams. *ESAIM Control Optim. Calc. Var.*, Vol. **13**, no. 3 (2007), 419-457.

- [49] A. GAUDIELLO, E. ZAPPALE, Junction in a thin multidomain for a fourth order problem. *Math. Models Methods Appl. Sci.* **16** (12) (2006), 1887-1918.
- [50] A. GOUSSEV, R.G. LUND, J.M. ROBBINS, V. SLASTIKOV, C. SONNENBERG, Domain wall motion in magnetic nanowires: an asymptotic approach. *Proc. R. Soc. Lond. Ser. A Math. Phys. Eng. Sci.* **469** (2013), no. 2160, 20130308, 18 pp.
- [51] G. GRISO, Asymptotic behavior of structures made of plates. *Anal. Appl.*, **3**(4) (2005), 325-356.
- [52] G. GRISO, Asymptotic behavior of structures made of curved rods. *Anal. Appl.*, **6**(1) (2008), 11-12.
- [53] P. HORNING, S. NEUKAMM, I. VELČIĆ, Derivation of a homogenized nonlinear plate theory from 3d elasticity. *Calc. Var. Partial Differ. Equ.* **51**, (2014) 677-699.
- [54] P. HORNING, I. VELČIĆ, Derivation of a homogenized von-Kármán shell theory from 3D elasticity. *Ann. Inst. Henri Poincaré, Anal. Non Linéaire* **32**(5) (2015) 1039–1070.
- [55] P. HORNING, I. VELČIĆ, Regularity of intrinsically convex $W^{2,2}$ surfaces and a derivation of a homogenized bending theory of convex shells. *J. Math. Pures Appl.* **115** (2018), 1-23.
- [56] H. LE DRET, Model of a junction between two rods. *J. Math. Pures. Appl.* , **68** (1989), 365-397.
- [57] H. LE DRET, Problèmes variationnels dans le multi-domaines: modélisation des jonctions et applications. *Research in Applied Mathematics*, **19**. Masson, Paris, 1991.
- [58] H. LEDRET, A. RAOULT, The nonlinear membrane model as a variational limit of nonlinear three-dimensional elasticity. *J. Math. Pures Appl.* **73**, (1995) 549-578.
- [59] H. LEDRET, A. RAOULT, The membrane shell model in nonlinear elasticity: a variational asymptotic derivation. *J. Nonlinear Sci.* **6**, (1996) 59-84.
- [60] M. LEWICKA, M.G. MORA, M. R. PAKZAD, Shell theories arising as low energy Γ -limit of 3d nonlinear elasticity. *Ann. Sc. Norm. Super. Pisa Cl. Sci. (5)* **9**, no. 2, (2010) 253-295.
- [61] M. LEWICKA, M. PAKZAD, The infinite hierarchy of elastic shell models: some recent results and a conjecture, In: Infinite dimensional dynamical systems. *Fields Inst. Commun.*, Vol. **64**, Springer, New York (2013), 407-420.
- [62] M. LEWICKA, M.R. PAKZAD, L. MAHADEVAN, The Föppl-von Kármán equations for plates with incompatible strains. *Proc. R. Soc. London, Ser. A* **467** (2011), 402-426.

- [63] T. MITSUI, I. TAKSUZAKI, E. NAKAMURA, An introduction to the physics of ferroelectrics. *Gordon and Breach, London, New York*, 1976.
- [64] M.G. MORA AND S. MULLER, Convergence of equilibria of three-dimensional thin elastic beams. *Proc. Roy. Soc. Edinburgh*, 138A (2008), 873–896.
- [65] S. NEUKAMM, Homogenization, linearization and dimension reduction in elasticity with variational methods. PhD thesis, *Technische Universität München*, (2010).
- [66] S. NEUKAMM, Rigorous derivation of a homogenized bending-torsion theory for inextensible rods from three-dimensional elasticity. *Arch. Ration. Mech. Anal.* **206** (2012), 645-706.
- [67] A. RAOULT, Non-polyconvexity of the stored energy function of a Saint-Venant-Kirchhoff material. *Aplikace Matematiky* **6** (1986), 417-419.
- [68] A. ROMANO, E.S. SUHUBI, Structure of Weis domain in ferroelectric crystals. *Int. J. Engng. Sci.* **30** (1992), 1715-1729.
- [69] D. SANCHEZ, Behaviour of the Landau-Lifschitz equation in a ferromagnetic wire. *Math. Methods Appl. Sci.* **32** (2009), 167-205.
- [70] V. SLASTIKOV, C. SONNENBERG, Reduced models for ferromagnetic nanowires. *IMA J. Appl. Math.* **77** (2012), 220-235.
- [71] Y. SU, C.M. LANDIS, Continuum thermodynamics of ferroelectric domain evolution: theory, finite element implementation, and application to domain wall pinning. *J. Mech. Phys. Solids* **55** (2007), 280-305.
- [72] J. TAMBACA AND I. VELČIĆ, Derivation of the nonlinear bending-torsion model for a junction of elastic rods. *Proc. Roy. Soc. Edinburgh*, 142A (2012), 633–664.
- [73] I. VELČIĆ, Shallow shell models by Γ -convergence. *Math. Mech. Solids* **17** (2012), 781-802.
- [74] I. VELČIĆ, Nonlinear weakly curved rod by Γ -convergence. *J. Elasticity* **108** (2012), 125-150.
- [75] I. VELČIĆ, On the derivation of homogenized bending plate model, *Calc. Var. Partial Differ. Equ.* **53** (3-4) (2015) 561-586.
- [76] W. ZHANG, K. BHATTACHARYA, A computational model of ferroelectric domains. Part I. Model formulation and domain switching. *Acta Mater.*, **53** (2005), 185-198.

VARIATIONAL LIMITS OF PROBLEMS IN JUNCTION DOMAINS FOR FERROELECTRIC AND HYPERELASTIC MATERIALS BY REDUCTION OF DIMENSION

Pedro L. Hernández-Llanos

In this work, firstly we study the junction phenomena for two joined thin structures in two kind of context, the first: Ferroelectricity, starting from a non-convex and nonlocal 3D-variational model for the electric polarization in a T-junction of two orthogonal thin wires made of ferroelectric material, and using an asymptotic process based on dimensional reduction, we obtain different 1D variational models depending of the initially boundary condition. The second one context: Hyperelasticity with homogeneous material, starting from 3D nonlinear elasticity equations and using dimensional reduction and Γ -convergence analyze junction phenomena for two orthogonal joined thin beams and we obtain a 1D variational model composed of the elastic energy of the vertical beam and the horizontal beam.

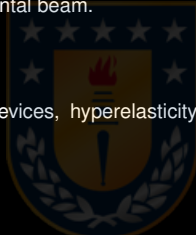

Keywords: Electric polarization, ferroelectric devices, hyperelasticity, thin wire, junctions, dimension reduction, gamma-convergence.

En este trabajo primeramente estudiamos el fenómeno de la unión para dos estructuras en dos tipos de contextos, el primero: Ferroelectricidad, iniciando desde un modelo tridimensional variacional no local y no convexo para la polarización eléctrica en una unión en forma de T de dos cables ortogonales hechos de material ferroeléctrico, y usando un proceso asintótico basado en reducción dimensional, obtenemos distintos modelos 1D dependiendo de las condiciones de frontera iniciales. El segundo contexto: Hiperelasticidad con material homogéneo, a partir de las ecuaciones de elasticidad tridimensional y usando reducción de dimensión y Γ -convergencia analizamos el fenómeno de la unión para dos vigas ortogonales unidas y obtenemos un modelo variacional 1D compuesto de la energía elástica de la viga vertical y la viga horizontal.

Palabras Claves: Polarización eléctrica, dispositivos ferroeléctricos, hiperelasticidad, cables delgados, uniones, reducción de dimensión, gamma-convergencia.

Programa de Doctorado en Matemáticas
Universidad de Concepción